

Contents

System description Safety remarks	3	Information on programming	50
System structure, conductor material and range		Initial commissioning/Login	51
Door area	4	Servicing	52-53
Network LAN	5	LED displays	54-55
Cabling for indoor devices	6	Glossary	56
System components		Index	57
Overview	7		
Door area	8-11		
Indoor devices	12-13		
Distribution	14-15		
Software	16-17		
Licences	18		
External devices	19		
Installation			
AS-AV Siedle Vario	20-21		
AS-AV Siedle Classic	22-23		
AS-AV Siedle Steel	24-25		
AS-AV Siedle Vario with supplementary supply	26-27		
AS-AV Siedle Vario with pilfer safeguard DSC 602-0	28-29		
AS-AV Siedle Vario with external camera	30-31		
AS-AV with Access custom-fit door loudspeaker and external camera	32-33		
AS-AV with Access custom-fit door loudspeaker and Access camera module	34-35		
AS-AV Siedle Vario with DRM 611-...	36-37		
AS-AV Siedle Vario with COM 611-...	38-39		
AS-AV external camera with video distributor	40-41		
AS-AV external camera	42-43		
AS-AA Siedle Vario	44-45		
AS-AA with Access custom-fit door loudspeaker	46-47		
Storey call button, customer's own signalling device	48-49		

System description

Safety remarks

Siedle Access is a powerful communication system based on groundbreaking IP technology. Communication is enabled both for audio and video and also for switching, control and signalling. The ideal field of application for the system is either in large properties or in any type of facility entailing complex technical requirements. Due to the central administration of the entire system, the work involved in commissioning and maintenance is kept to a minimum. The installation is based on network technology, making it extremely open for further expansion.

Commercial and private applications can be mixed or combined at will. Technology parks can be connected to administration or training centres under a single cohesive system, even across different buildings, while still retaining their own independent functions.

Generally speaking, a distinction is drawn between the door area and the protected local area network (LAN). A detailed description of these two areas is provided in the section System structure/conductor material.

Electrical voltage



Mounting, installation and servicing work on electrical devices may only be performed by a suitably qualified electrician. Failure to observe this regulation could result in the risk of serious damage to health or fatal injury due to electric shocks.

Electrostatic charging



As a result of electrostatic charging, direct contact with the circuit board can result in destruction of the device. Direct contact with the circuit board must therefore be avoided.

- When working at the device, observe the remarks relating to mains cut-off.
- Observe the DIN EN 60065 standard! When establishing the electronic connection, observe the requirements of VDE 0805 or EN 60950.
- The building installation must include an all-pole mains switch with a contact separation of at least 3 mm.
- Ensure maximum fusing of 16A for the mains connection in the building installation.
- When planning large-scale (complex) systems, the distributor space required for the switch panel mounting devices must be taken into consideration in the distributor planning process. No external voltages >30 V AC/DC may be applied to system users.

Devices with 230 V connection

In accordance with DIN VDE 0100 part 410, section 411.1.3 attention must be paid to ensuring a safe separation between system lines and the mains voltage; i.e. system and mains cores must not be permitted to touch! The system line cable (extra-low safety voltage) must be stripped back by the minimum possible.



During the update process, the power supply to the devices must not be interrupted, as this can result in damage. In this case, a repeat update is no longer possible, and the devices will have to be sent in for repair.

System structure, conductor material and range

Door area

Generally speaking, a distinction is drawn between the door area and the protected local area network (LAN).

Door area

The installation for the door station is referred to as the door area. If correctly installed, this area is protected from unauthorized access. From the outside, it is not possible to access the network.

Cabling in the door area

The IP network terminates with the ATLC/NG 670-...

To protect against unauthorized access, the ATLC/NG 670-... must be accommodated without fail inside the building.

The cabling from the ATLC/NG 670-... to the door station is executed in the conventional way.

Conductor material

CAT	AWG22
J-Y(ST)Y	twisted pair conductors, shielded

Range

Door controller to door station	
CAT AWG22	= 120 m
J-Y(ST)Y \varnothing 0,6 mm	= 100 m
J-Y(ST)Y \varnothing 0,8 mm	= 200 m

If an external camera is directly supplied, the distance between the AIVS 670-... and camera may increase to > 10 m. This range is dependent on the output signal of the camera and the quality of the coaxial cable used. The AIVS 670-... requires a video input signal of 1 Vss.

Every door station/independent camera is installed in the system with its own ATLC/NG 670-...

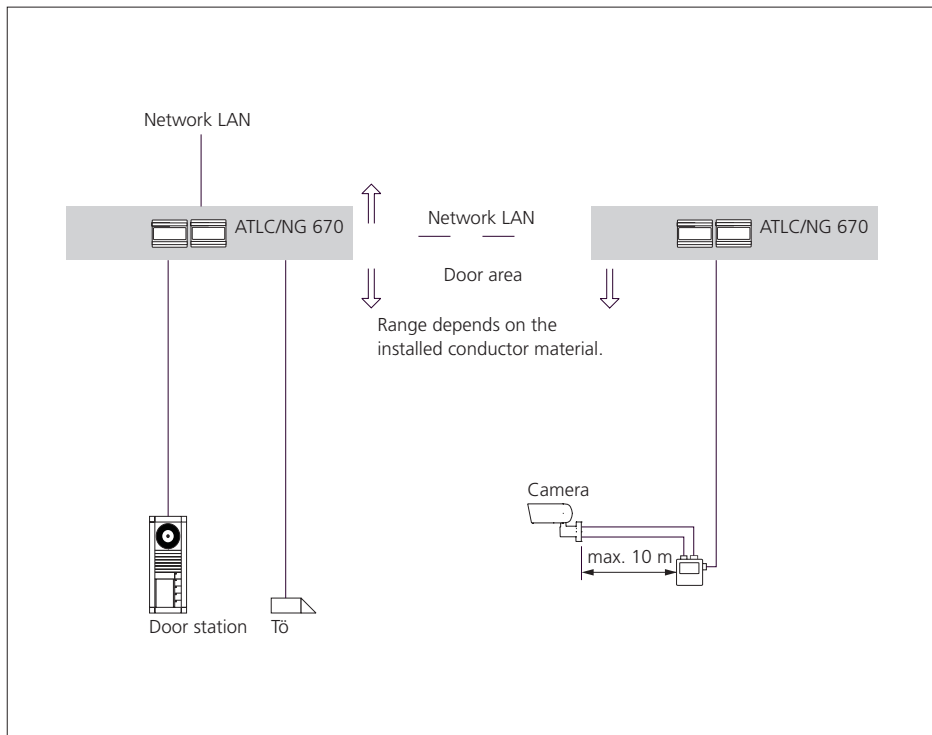

System structure, conductor material and range

Network LAN

Network LAN

The requirement for integration of an Access system is a network infrastructure created in accordance with the stipulations for generic cabling (from Category 5).

Rules for generic cabling are set out in various standards:

- DIN 50173-1 General requirements

For individual building types, the following standards apply in addition:

- DIN 50173-2 (ISO/IEC 11801) for office buildings
- DIN 50173-3 (ISO/IEC 24702) for industrially used locations
- DIN 50173-4 (ISO/IEC 15018) for apartments

Internationally, the ISO/IEC standards apply.

Cabling structure/areas

The cabling is broken down into 3 areas.

Primary area

- Fibre optic cables
- Cabling between individual buildings and/or within buildings between several main building distributors.
- In the case of copper wire connections, adequate equipotential bonding must be guaranteed.

Secondary area

- Fibre optic cables
- The storeys are networked by means of storey distributors. Both fibre optic and copper connections can be used. This is dependent upon the switches used and their distance from the main distributor/switch.

Tertiary area

- Twisted pair for fixed installation plus patch cable for cabling from the network junction box to the terminal.

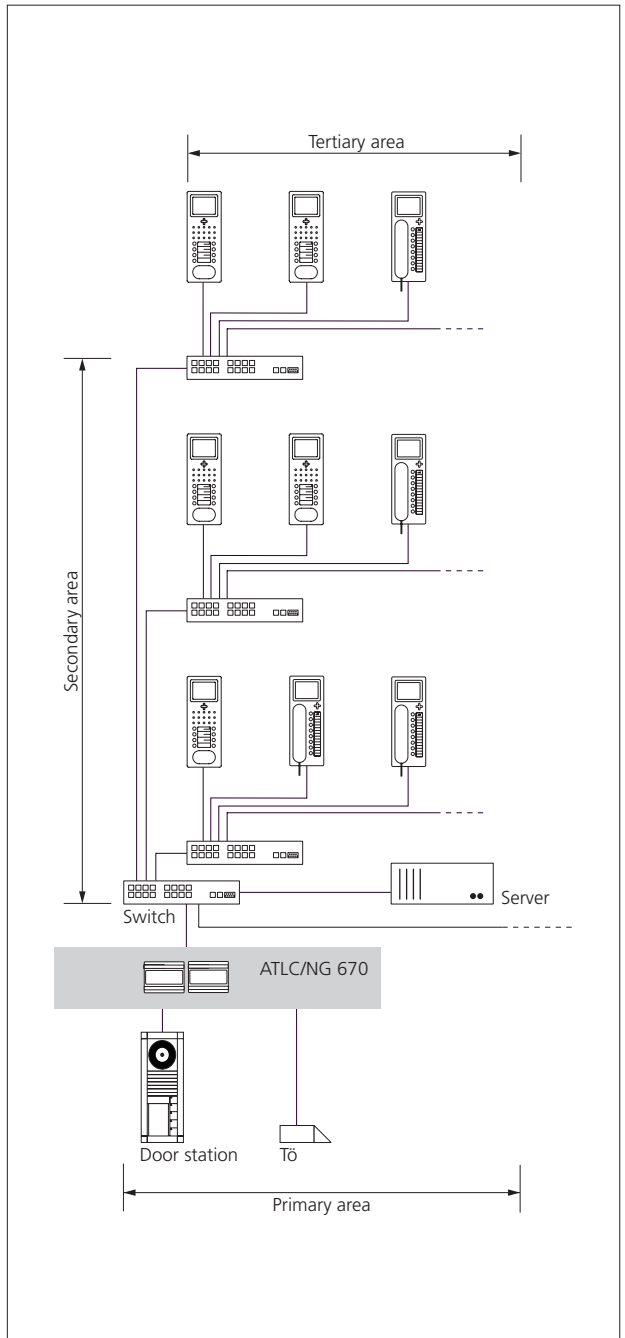

System structure, conductor material and range

Cabling for indoor devices

Cabling for indoor devices

The Access indoor devices can be installed without problems using standard RJ45 flush mounting network junction boxes.

In this case, simply install the network junction box without the frame and panel. The Siedle indoor device can be mounted above the junction box and connected to the network with a plug-in connector.

If there is no flush mounted network socket at the required mounting height due to circumstances on site, the indoor call station can be surface mounted with the AZA 870-... In this case, the connection from the indoor call station to the network is established using a patch cable (not provided).

If the indoor call station is intended for use as a table-top unit, the device can be converted using the AZTV 870-... with 3 metre long connecting cable.



An indoor device may only be connected to the network using an RJ45 8/8 (8) network socket.

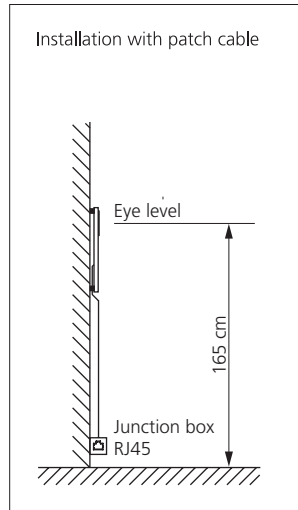
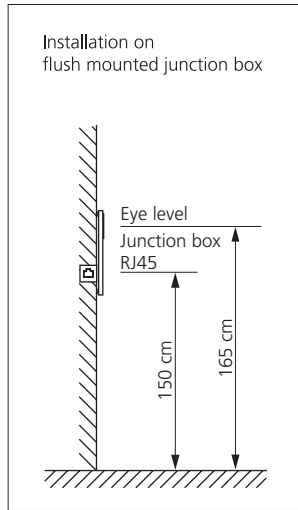

System components

Overview

Devices integrated in the LAN network (protected area) are linked by an interface to the door.

Devices assigned to the door area.

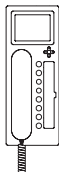

AHT 870-...
AHTV 870-...

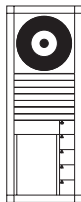

ATLM 670-...,
ACM 670-...,

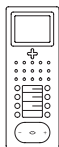

AHF 870-...
AHFV 870-...



ATLE 670-...,

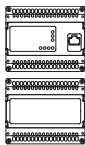

ATLC/NG 670-...

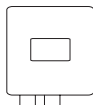

AIVS 670-...



AS 670-... S



AS 670-... M, L

System components

Door area

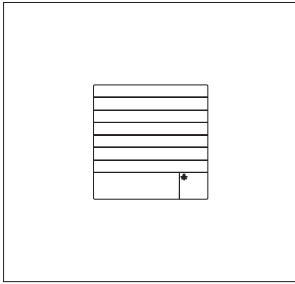

ATLM 670-0

Access door loudspeaker module in 611 Vario design.

Complete module with loudspeaker, microphone and light button with LED illuminated light symbol.

Up to max. 48 call button modules can be connected in any optional combination, allowing up to max. 192 users.

Acoustic feedback when actuating the call button at the BTM 650-01 to -04 optional.

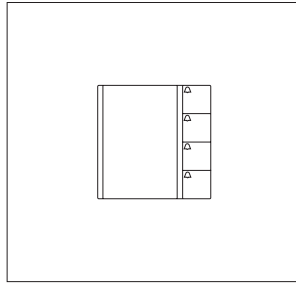

BTM 650-01 to 04

Bus call button modules BTM 650-... with 1, 2, 3 or 4 call buttons. The BTM 650-... is connected to the ATLM 670-... via ribbon cable.

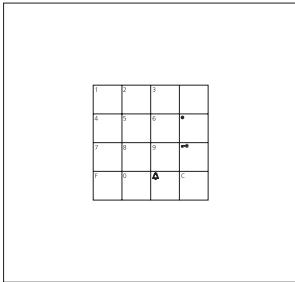

COM 611-02

Code lock module as an input device for the placement of door calls and control functions in conjunction with Access and the Siedle access control system.

- With keypad for making calls or
- For controlling in conjunction with the Easikey controller EC 602...
- C button for cancelling incorrect inputs
- DR button for direct door release via the EC 602-...

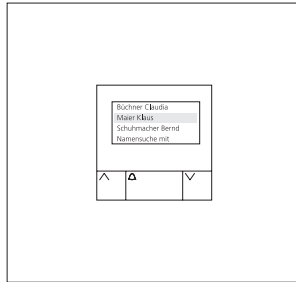

DRM 611-01

Display call module as an input device with 4-line display for placing door calls.

Indication of names in the display in alphabetical order.

The DRM 611-... can also be used in combination with the COM 611-... in order to display the input via the COM 611-...

The PRI 602-... USB and the ZWA 640 are required for programming.

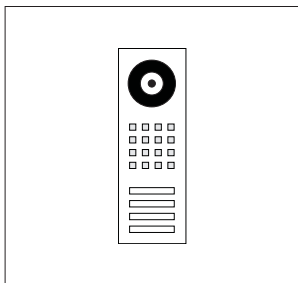

Siedle Steel STL...

Door station in the Steel design line, with stainless steel front, door loudspeaker, call buttons and Access camera. LED-illuminated bell buttons, 3 mA, 12 V AC each per button.

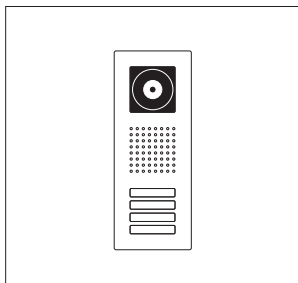

Siedle Classic

Door station in the Classic design line, with stainless steel front, door loudspeaker, call buttons and Access camera. LED-illuminated bell buttons, 5 mA, 12 V AC each per button.

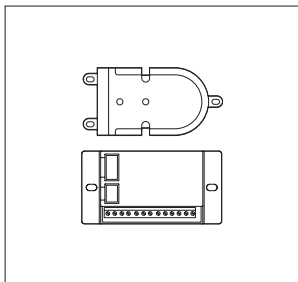

ATLE 670-0

Access custom-fit door loudspeaker with bus call button matrix for mounting in a loudspeaker compartment, door constructions, letter-boxes etc.

12 of the client's own call buttons can be directly connected at the bus call button matrix BRMA 050-...
Control output for external camera, connection of existing buttons via BRMA 050-...

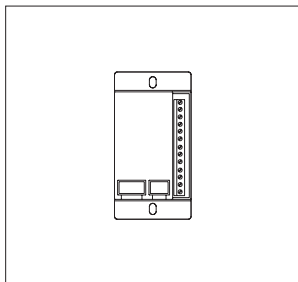

BRMA 050-01

Bus call button matrix for the connection of existing call buttons to the custom-fit door loudspeaker BTLE 050-.../ATLE 670-...

Max. 14 BRMA 050-... can be connected to 1 BTLE 050-...

Max. 16 BRMA 050-... can be connected to 1 ATLE 670-...

System components

Door area

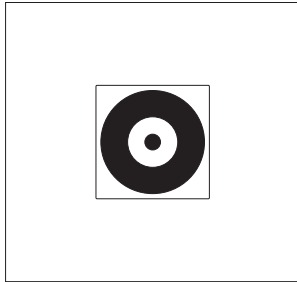

ACM 670-0

Access camera module for mounting in Siedle Vario 611-housing.

Performance features:

- Integrated heating with 2-stage temperature control
- Infrared lighting and control electronics
- Colour system PAL
- Image pick-up CCD sensor 8.4 mm (1/3") 752 x 582 pixel (horizontal/vertical)
- Lens attachment 2.9 mm
- Automatic day/night switchover at approx. 4 lux (from colour to monochrome) for optimized quality
- Pick-up angle vertical 60°, horizontal 80°
- Additional mechanical adjustment range 30° horizontal and vertical
- Horizontal resolution 450 lines

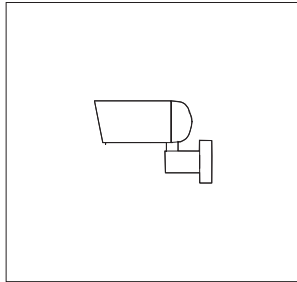

CEC 612-0

Day/night CCD video camera for external mounting, in weather-proof housing and wall arm with ball head, internal cable routing.

- Image pick-up colour CCD sensor 8.4 mm (1/3"); 752 (H) x 582 (V) 440.000 pixel
- Zoom-lens attachment 3.8–9.5 mm, F 1,2, with IR filter, automatic swivel action
- Pick-up angle 74°–30°
- Light sensitivity 0.5 Lux in colour mode and 0.24 Lux in monochrome mode, each at F 1.2
- Backlight compensation
- Automatic white balance
- Resolution horizontal 480 TV lines
- Video signal 1 Vpp, FBAS, at 75 Ohm

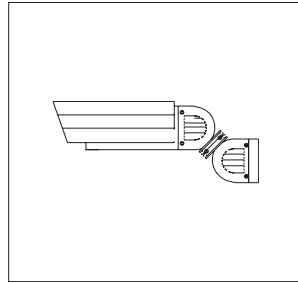

KA/WG 950-0 C

Day/night CCD video camera for external mounting, with weather-proof housing and sun shade, wall arm with ball head and internal wiring.

- Image pick-up colour CCD sensor 6.3 mm (1/4"); 752 (H) x 582 (V) 400,000 pixel
- Lens attachment 3.9–85.9 mm without IR filter
- Pick-up angle 50°–2.5°
- Light sensitivity 0.8 Lux at F 1,2
- Resolution horizontal 480 TV lines
- Video signal 1 Vpp at 75 Ohm
- Connecting cable in wall arm

ZNF 950-0

Line rectifier foot accessory for the camera KA/WG 950-..., for supplying from the 230 V network. The cameras are connected by plug-in connections.

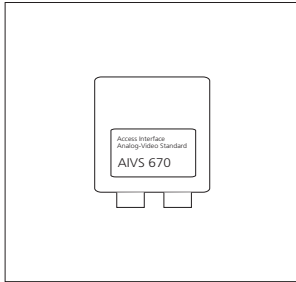

AIVS 670-0

Access analog video standard interface in surface-mount housing for connection of an analog camera to the ATLC 670-...

Following a door call, the picture from the analog camera automatically appears on the Access indoor call station. Manual selection of the door is also possible. The camera cannot be controlled.

The connection of analogue cameras generally takes place via the Access interface analogue-video standard AIVS 670-...

System components

Indoor devices, Accessory

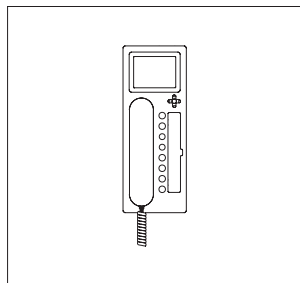

AHT 870-0

Access in-house telephone with door release button and 7 additional buttons with 2-colour status LED.

All buttons are freely programmable. The display shows the graphic menu interface, but not a camera image. It is possible to upgrade to a fully functional video station.

With the functions calling, speech, door release, light, remote switching and call silencing.

With the additional purchase of licence ALUV 270-..., the AHT 870-... can be converted into a fully functional indoor video device.

Performance features:

- Display 8.8 cm
- Entrance for storey calls
- Exit freely programmable
- Call differentiation between door calls, storey calls, indoor calls and concierge calls
- Switching functions
- Status indications
- Can be used with table-top accessory AZTV 870-... as a table-top device

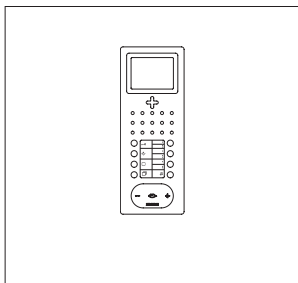

AHF 870-0

Access handsfree telephone with speech/control button, door release button and 7 additional buttons with 2-colour status LED. All buttons are freely programmable. The display shows the graphic menu interface, but not a camera image. It is possible to upgrade to a fully functional video station.

With the functions calling, speech, door release, light, remote switching and call silencing.

With the additional purchase of licence ALUV 270-... the AHF 870-... can be converted into a fully functional indoor video device.

Performance features:

- Display 8.8 cm
- Entrance for storey calls
- Exit freely programmable
- Call differentiation between door calls, storey calls, indoor calls and concierge calls
- Switching functions
- Status indications
- Can be used with table-top accessory AZTV 870-... as a table-top device

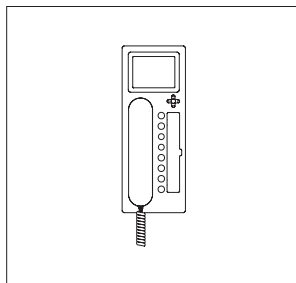

AHTV 870-0

Access in-house telephone video with door release button and 7 additional buttons with 2-colour status LED. All buttons are freely programmable. The display shows the camera image and the graphic menu interface.

With the functions calling, speech, door release, vision, light, remote switching and call silencing.

Performance features:

- Display 8.8 cm
- Entrance for storey calls
- Exit freely programmable
- Call differentiation between door calls, storey calls, indoor calls and concierge calls
- Switching functions
- Status indications
- Video memory function
- Integrated 5-way control button
- Can be used with table-top accessory AZTV 870-... as a table-top device

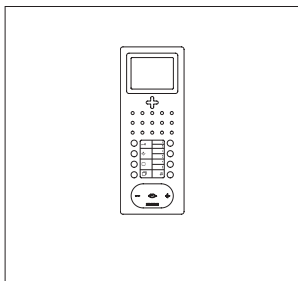

AHFV 870-0

Access handsfree telephone video with speech/control button, door release button and 7 additional buttons with 2-colour status LED. All buttons are freely programmable. The display shows the camera image and the graphic menu interface. With the functions calling, speech, door release, vision, light, remote switching and call silencing.

Performance features:

- Display 8.8 cm
- Entrance for storey calls
- Exit freely programmable
- Call differentiation between door calls, storey calls, indoor calls and concierge calls
- Switching functions
- Status indications
- Video memory function
- Integrated 5-way control button
- Can be used with table-top accessory AZTV 870-... as a table-top device

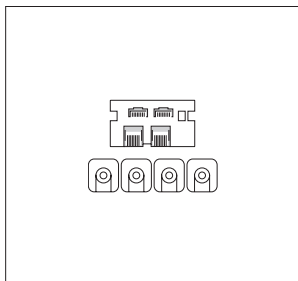

AZA 870-0

Access surface-mount accessory, for professional surface mounting of Access indoor call stations. Comprises a connection adapter and 4 spacers. The raised height is increased by 8 mm.

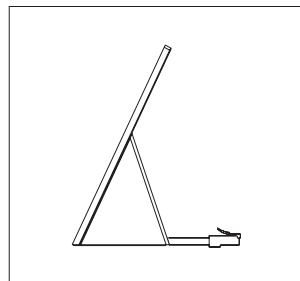

AZTV 870-0

Access table-top accessory for indoor call stations for converting from a wall to a table-top device. Slip-proof console.

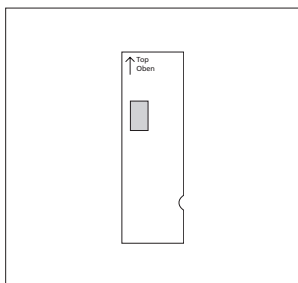

AZIO 870-0

Access input/output accessory as circuit board for integration in an indoor unit with an additional input/output.

System components

Distribution

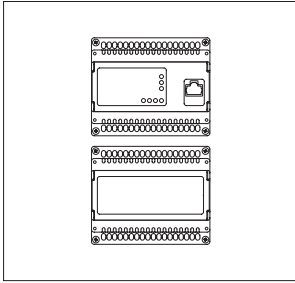

ATLC/NG 670-0

Access door loudspeaker controller with line rectifier in switch panel housing as an interface for the connection and power supply of door components to the Access network. Switch contact for door release and freely programmable switching input.

Admissible switching output:

- Light bulbs max. 1300 W
- Fluorescent lamps max. 800 W
- Twin fluorescent lamps max. 1200 W
- Parallel compensated fluorescent lamps max. 400 W

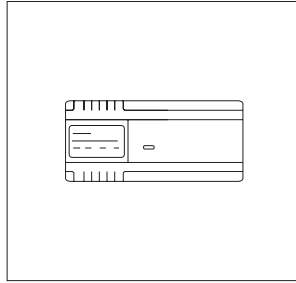

VNG 602-02

Video line rectifier in a 10-grid housing.

Primary: 230 V AC, 50/60 Hz
Secondary: 30 V DC, 1.1 A stabilized.

For the supply of individual components such as external cameras.

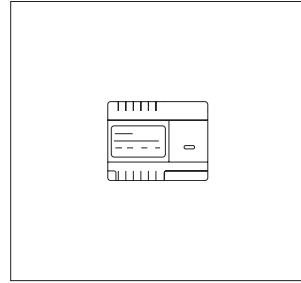

TR 602-01

Transformer in switch panel housing, to supply supplementary components.

Operating voltage: 230 V AC
+/-10 %, 50/60 Hz

Output voltage: 12 V AC

Output current: max. 2.5 A

Dimensions (mm) W x H x D:

107 x 89 x 60

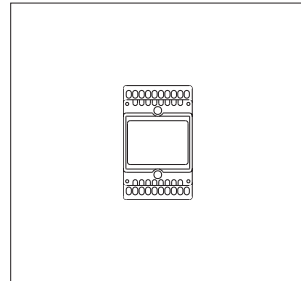

TR 603-0

Transformer in switch panel housing, to supply supplementary components.

Operating voltage: 230 V AC
+/-10 %, 50/60 Hz

Output voltage: 12 V AC

Output current: max. 1.3 A

Dimensions (mm) W x H x D:

53.5 x 89 x 60

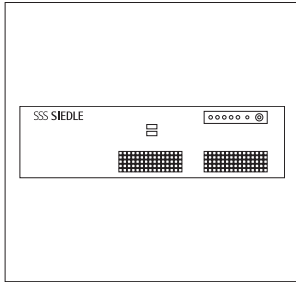

AS 670-0 S

Access Server in metal housing, suitable for top hat rail mounting, as a central unit for management of the entire Access system; Expansion possible up to 50 users.

More than 10 connections may exist at any one time in the system.

Commissioning takes place in the complete system.

Dimensions (mm) W x H x D:

328 x 88.8 x 201

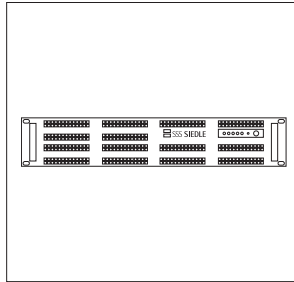

AS 670-0 M

Access server in 19" housing as a central unit for managing the entire Access system. Expansion possible up to 500 users.

More than 10 connections may exist at any one time in the system.

Commissioning takes place in the complete system.

Dimensions (mm) W x H x D:

483 x 88 x 460

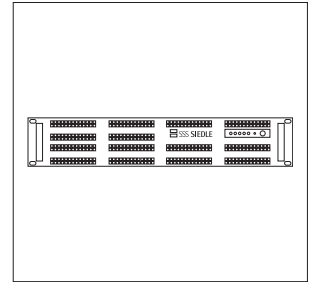

AS 670-0 L

Access server in 19" housing as a central unit for managing the entire Access system. Expansion possible from 500 to over 1000 users.

More than 10 connections may exist at any one time in the system.

Commissioning takes place in the complete system.

Dimensions (mm) W x H x D:

483 x 88 x 460

Software

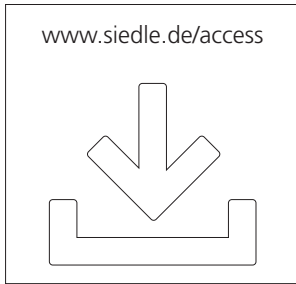

ASHT 170-0

Access in-house telephone software, which graphically depicts a virtual in-house telephone with video on a PC monitor.

- Door calls with video are possible to a Siedle door station.
- Indoor calls possible
- Execution of switching and control functions such as door release, light switching etc.
- Display of signals

Function overview:

- Call differentiation between door calls, storey calls, indoor calls and concierge calls
- Device and user overview
- Users, doors and devices can be selected from lists
- Global/private address books
- Video memory function over licence ALZV 270-...
- Status displays of switchgear
- Switching functions for external relays

System requirements:

- Microsoft® Windows XP (from SP3, 32 Bit)
- Microsoft® Windows Vista Home Premium and Business (from SP1, 32/64 Bit)
- Microsoft® Windows 7 Home Premium, Professional and Ultimate (32/64 Bit)
- Intel® Pentium® IV from 2.0 GHz or compatible CPUs
- min. 2 GB RAM
- Graphics card with at least 128 MB RAM DirectX 9 support and 16 bit colour depth
- Ethernet card 100 Mbit
- Sound card including headset adapter
- .NET Framework 4.0

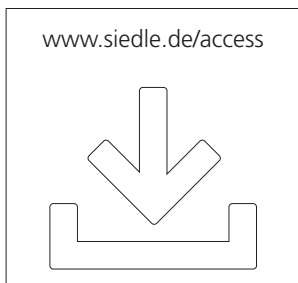

ASC 170-0

Access concierge software, the central interface at the reception desk. Due to the wide selection of possible control functions and statuses, and facility for supporting several calls and video links, this application is ideally suited as a communication switchboard.

Function overview:

- Several audio and video links can be depicted simultaneously
- Convenient forwarding functions
- Music-on-hold
- Status overview of all Doormatic door statuses, e.g. activation enabled day/night switchover
- Convenient switching/control and display functions
- Camera scan function
- Answering machine functions

System requirements:

- Microsoft® Windows XP (from SP3, 32 Bit)
- Microsoft® Windows Vista Home Premium and Business (from SP1, 32/64 Bit)
- Microsoft® Windows 7 Home Premium, Professional and Ultimate (32/64 Bit)
- Intel® Pentium® IV from 2.0 GHz or compatible CPUs
- min. 2 GB RAM
- Graphics card with at least 1280 x 720, 128 MB RAM, DirectX 9 support and 16 bit colour depth
- Ethernet card 100 Mbit
- Sound card including headset adapter
- .NET Framework 4.0

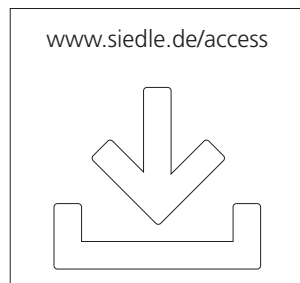

ASM 170-0

Access software module for integration of Siedle Access in external systems, e.g. touch panels. You will be kept up to date with the latest information by our Project Sales Department

Licences

ALT 270-0

Access telephony connection licence for utilization of an external connection channel.

A separate licence is required per channel.

The use of non-Siedle devices is subject to Siedle approval.

ALFV 270-0

Access licence for non-Siedle video device for connection of a VoIP video telephone to the Access system.

The use of non-Siedle devices is subject to Siedle approval.

ALFA 270-0

Access licence for non-Siedle audio device for connection of a VoIP audio telephone to the Access system.

Using a VoIP-ATA adapter, it is also possible to connect an analog telephone.

The use of non-Siedle devices is subject to Siedle approval.

ALFS 270-0

The external smartphone Access licence permits connection to the Access server.

A separate licence is required per device. The smartphone functions as a mobile indoor device with video.

An additional App is required for operation. This must be purchased from the App Store.

ALFT 270-0

The external tablet Access licence permits connection to the Access server.

A separate licence is required per device. The tablet functions as a mobile indoor device with video.

An additional App is required for operation. This must be purchased from the App Store.

ALKNX 270-0 <50

Access KNX connection licence for importing and managing KNX addresses. A maximum of 50 data points can be assigned.

KNX telegrams can be sent and received.

ALKNX 270-0 <300

Access KNX connection licence for importing and managing KNX addresses. A maximum of 300 data points can be assigned.

KNX telegrams can be sent and received.

ALKNX 270-0 <1000

Access licence KNX connection for the import and management of KNX addresses; assignment of up to 1000 data points.

KNX telegrams can be sent and received.

External devices

For many requirements and ideas, the market is flooded by a large number of devices. Communication and compatibility between the different components can sometimes be an issue. For this reason, it is advisable to make contact at an early stage with our project sales department.

We are currently able to offer recommendations for the following areas.

Analogue telephone adapter ATA

SIP telephone

Switch actuators

KNX

VoIP

Interface ISDN telephone system

If required, we are glad to also test other interesting areas.

Installation

AS-AV Siedle Vario

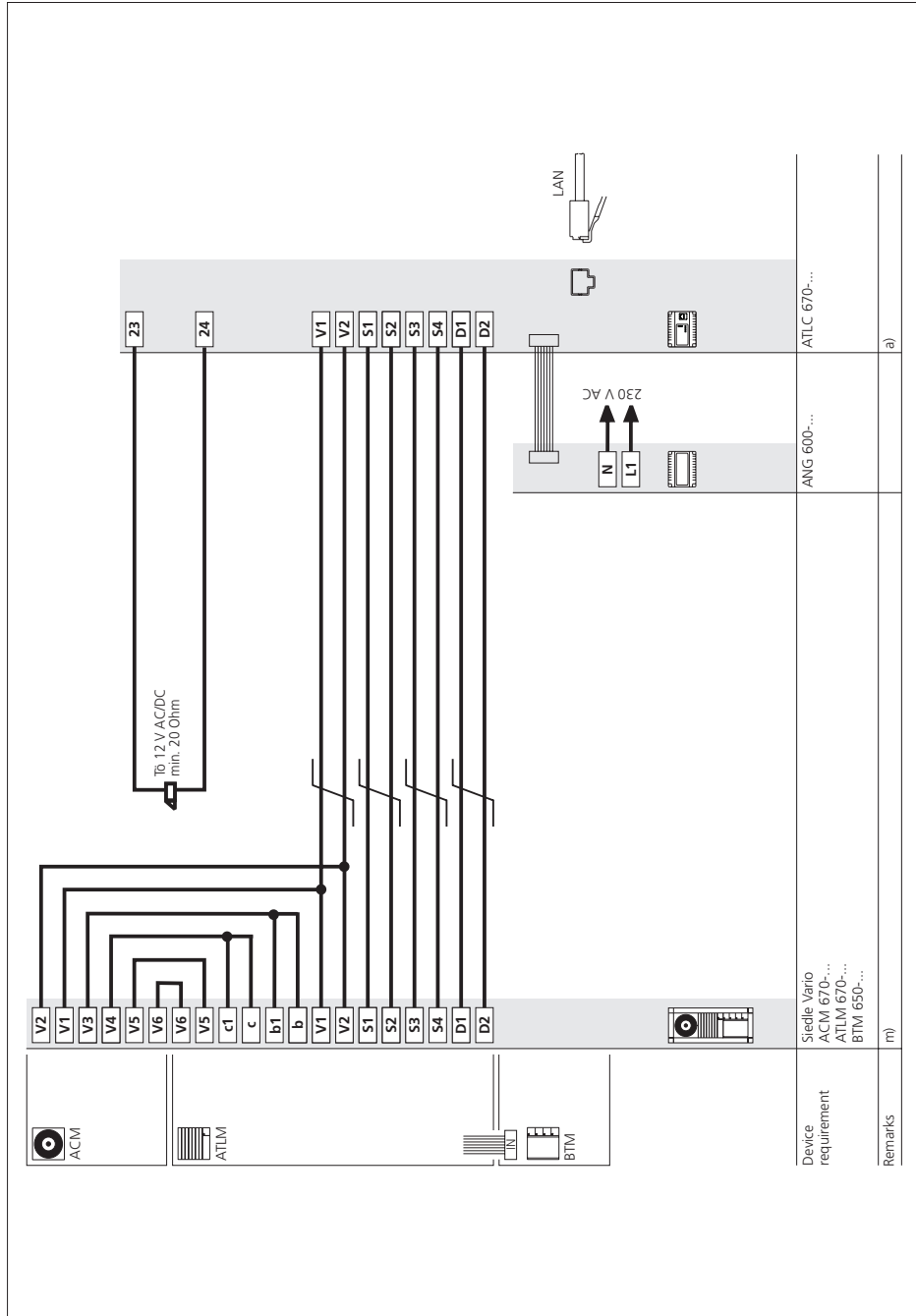

Functional

Calling, speech and video functions between door station and the connected Access indoor call stations. An existing call can not be listened in to or viewed by other Access indoor call stations. Door release button for the door release function and 7 other buttons which can be assigned any optional functions. The definition of functions and the relevant buttons take place during configuration of the server which assumes the function of central overall system administrator. The number of Access users is determined by the server. Connection facility for a storey call button (ERT) for calling an apartment door and potential-free contact is available as standard. Different ringtones for calling from the front door, the apartment door, concierge or internal call.

Supplementary functions

- Internal calls and speech communication between Access indoor call stations are possible.
- Connection of an analogue camera to the ATLC 670-... via the interface AIVS 670-...
- Concierge function as central interface, e.g. at the reception
- 8 freely selectable ring tones
- Call forwarding
- Call follow-me function
- Parallel door and storey call
- Group formation possible
- Selective dialling of the door station using additional free buttons
- Central video memory module (server) possible

Remarks

- a)** If door release or door control systems are installed which do not correspond to 12 V AC/DC min. 20 Ohm, the system will require an intermediate relay.
- m)** Where there are more than 10 BTM 650-... units, an additional 12 V AC supply, for instance TR 603-..., must be installed due to the current consumption.

Installation

AS-AV Siedle Classic

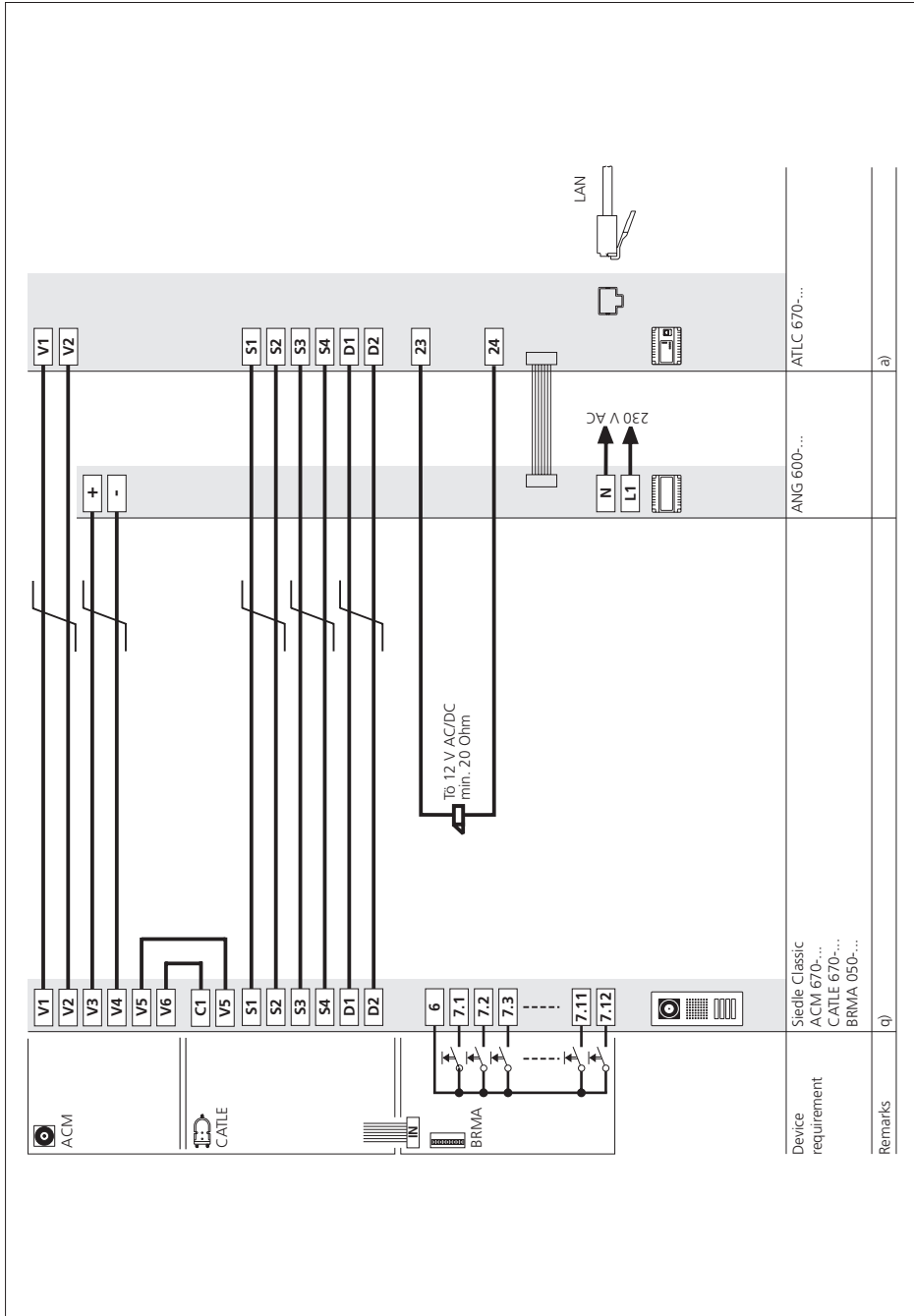

Device requirement
Siedle Classic
ACM 670-...
CATLE 670-...
BRMA 050-...

ANG 600-...
ATLC 670-...

Remarks

a)

q)

Functional

Calling, speech and video functions between door station and the connected Access indoor call stations. An existing call can not be listened in to or viewed by other Access indoor call stations. Door release button for the door release function and 7 other buttons which can be assigned any optional functions. The definition of functions and the relevant buttons take place during configuration of the server which assumes the function of central overall system administrator. The number of Access users is determined by the server. Connection facility for a storey call button (ERT) for calling an apartment door and potential-free contact is available as standard. Different ringtones for calling from the front door, the apartment door, concierge or internal call.

Supplementary functions

- Internal calls and speech communication between Access indoor call stations are possible.
- Connection of an analogue camera to the ATLC 670-... via the interface AIVS 670-...
- Concierge function as central interface, e.g. at the reception
- 8 freely selectable ring tones
- Call forwarding
- Call follow-me function
- Parallel door and storey call
- Group formation possible
- Selective dialling of the door station using additional free buttons
- Central video memory module (server) possible

Remarks

- a)** If door release or door control systems are installed which do not correspond to 12 V AC/DC min. 20 Ohm, the system will require an intermediate relay.
- q)** The internal wiring of the Classic door station is completed on site by the customer.

Installation

AS-AV Siedle Steel

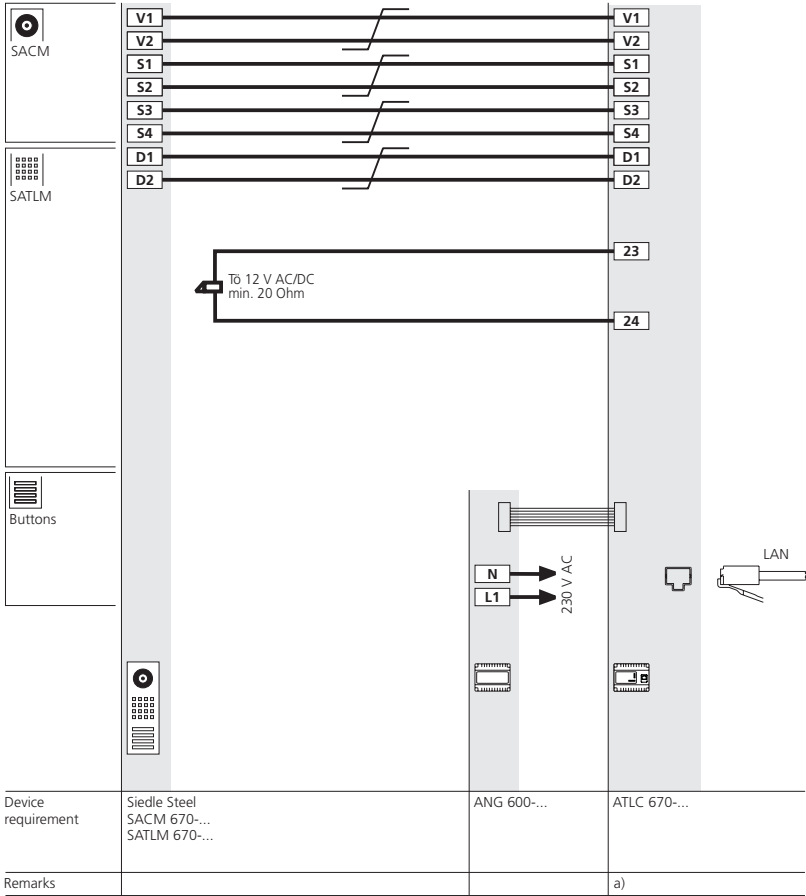

Functional

Calling, speech and video functions between door station and the connected Access indoor call stations. An existing call can not be listened in to or viewed by other Access indoor call stations. Door release button for the door release function and 7 other buttons which can be assigned any optional functions. The definition of functions and the relevant buttons take place during configuration of the server which assumes the function of central overall system administrator. The number of Access users is determined by the server. Connection facility for a storey call button (ERT) for calling an apartment door and potential-free contact is available as standard. Different ringtones for calling from the front door, the apartment door, concierge or internal call.

Supplementary functions

- Internal calls and speech communication between Access indoor call stations are possible.
- Connection of an analogue camera to the ATLC 670-... via the interface AIVS 670-...
- Concierge function as central interface, e.g. at the reception
- 8 freely selectable ring tones
- Call forwarding
- Call follow-me function
- Parallel door and storey call
- Group formation possible
- Selective dialling of the door station using additional free buttons
- Central video memory module (server) possible

Remarks

a) If door release or door control systems are installed which do not correspond to 12 V AC/DC min. 20 Ohm, the system will require an intermediate relay.

Installation

AS-AV Siedle Vario with supplementary supply

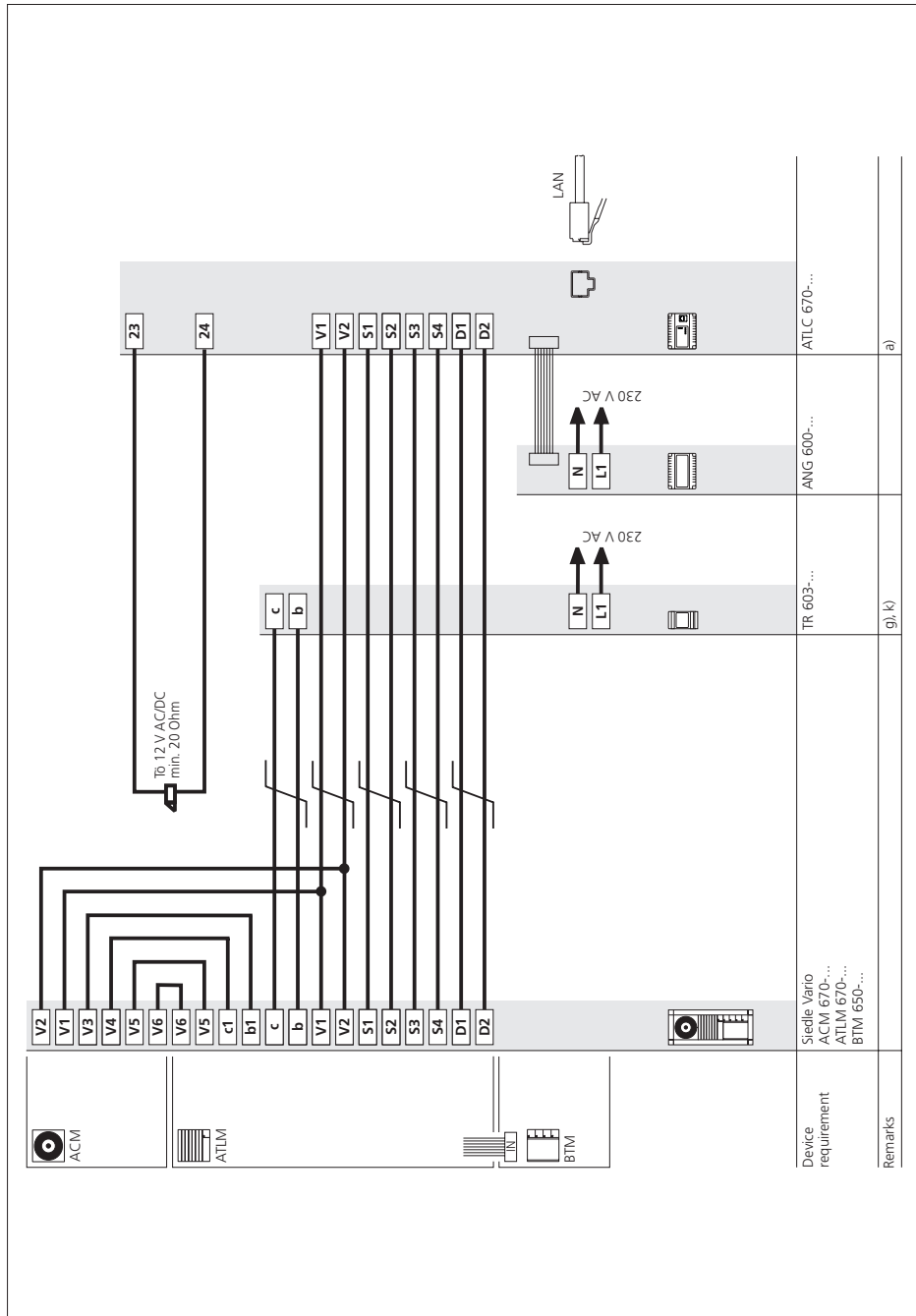

Functional

Calling, speech and video functions between door station and the connected Access indoor call stations. An existing call can not be listened in to or viewed by other Access indoor call stations. Door release button for the door release function and 7 other buttons which can be assigned any optional functions. The definition of functions and the relevant buttons take place during configuration of the server which assumes the function of central overall system administrator. The number of Access users is determined by the server. Connection facility for a storey call button (ERT) for calling an apartment door and potential-free contact is available as standard. Different ringtones for calling from the front door, the apartment door, concierge or internal call.

Supplementary functions

- Internal calls and speech communication between Access indoor call stations are possible.
- Connection of an analogue camera to the ATLC 670-... via the interface AIVS 670-...
- Concierge function as central interface, e.g. at the reception
- 8 freely selectable ring tones
- Call forwarding
- Call follow-me function
- Parallel door and storey call
- Group formation possible
- Selective dialling of the door station using additional free buttons
- Central video memory module (server) possible

Remarks

- a)** If door release or door control systems are installed which do not correspond to 12 V AC/DC min. 20 Ohm, the system will require an intermediate relay.
- g)** Is only required if more than 10 BTM 650-... units are installed at this door station.



- k)** If the BTM 650-... units are supplied via a separate transformer, no connection between c1 and c/b1 and b may exist at the terminal block.

AS-AV Siedle Vario with pilfer safeguard DSC 602-0

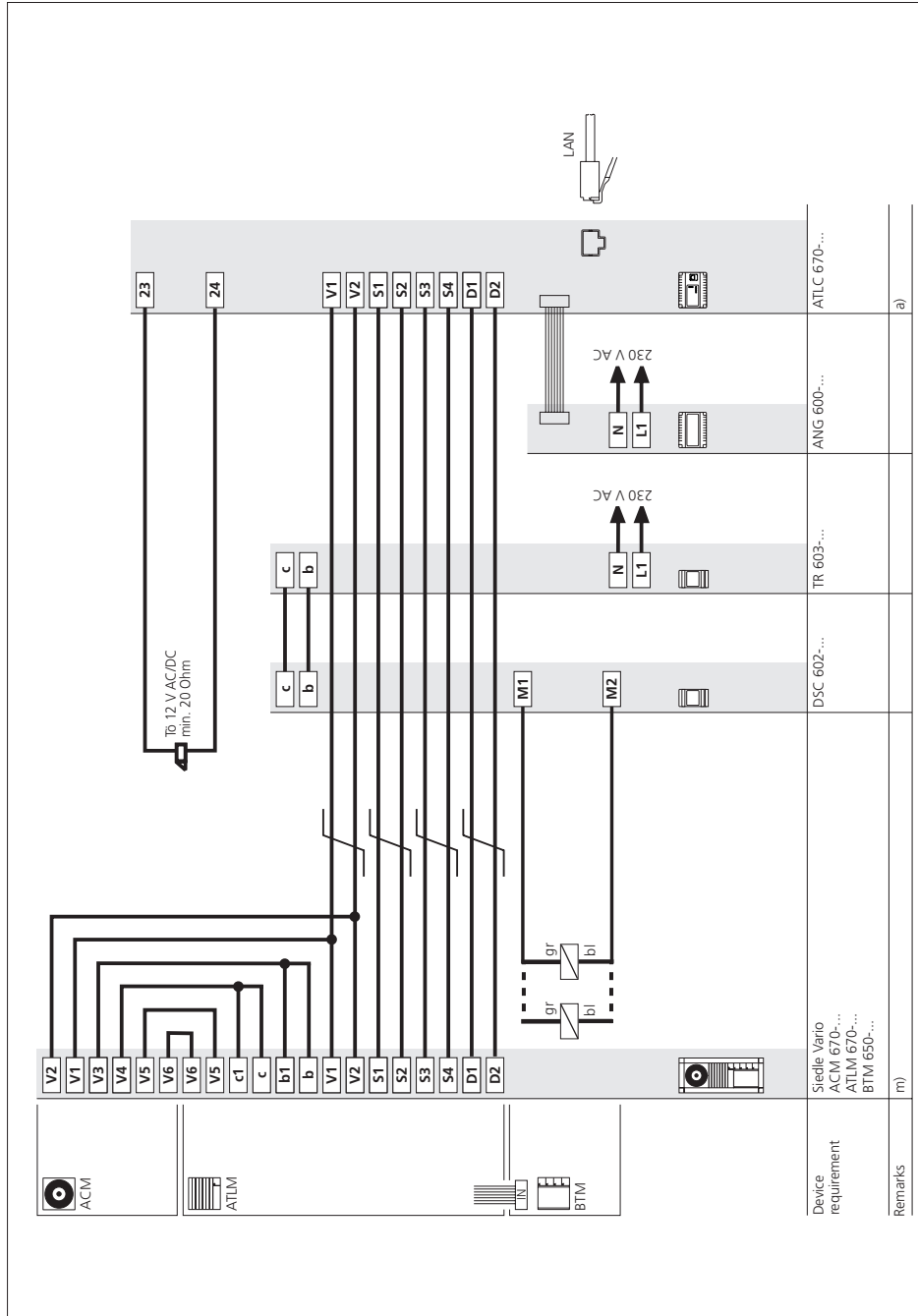

Functional

Calling, speech and video functions between door station and the connected Access indoor call stations. An existing call can not be listened in to or viewed by other Access indoor call stations. Door release button for the door release function and 7 other buttons which can be assigned any optional functions. The definition of functions and the relevant buttons take place during configuration of the server which assumes the function of central overall system administrator. The number of Access users is determined by the server. Connection facility for a storey call button (ERT) for calling an apartment door and potential-free contact is available as standard. Different ringtones for calling from the front door, the apartment door, concierge or internal call. The mounting frame can be locked/unlocked using the DSC 602-... This protects the integrated modules against unauthorized removal.

Supplementary functions

- Internal calls and speech communication between Access indoor call stations are possible.
- Connection of an analogue camera to the ATLC 670-... via the interface AIVS 670-...
- Concierge function as central interface, e.g. at the reception
- 8 freely selectable ring tones
- Call forwarding
- Call follow-me function
- Parallel door and storey call
- Group formation possible
- Selective dialling of the door station using additional free buttons
- Central video memory module (server) possible

Remarks

- a)** If door release or door control systems are installed which do not correspond to 12 V AC/DC min. 20 Ohm, the system will require an intermediate relay.
- m)** Where there are more than 10 BTM 650-... units, an additional 12 V AC supply, for instance TR 603-..., must be installed due to the current consumption.

Installation

AS-AV Siedle Vario with external camera

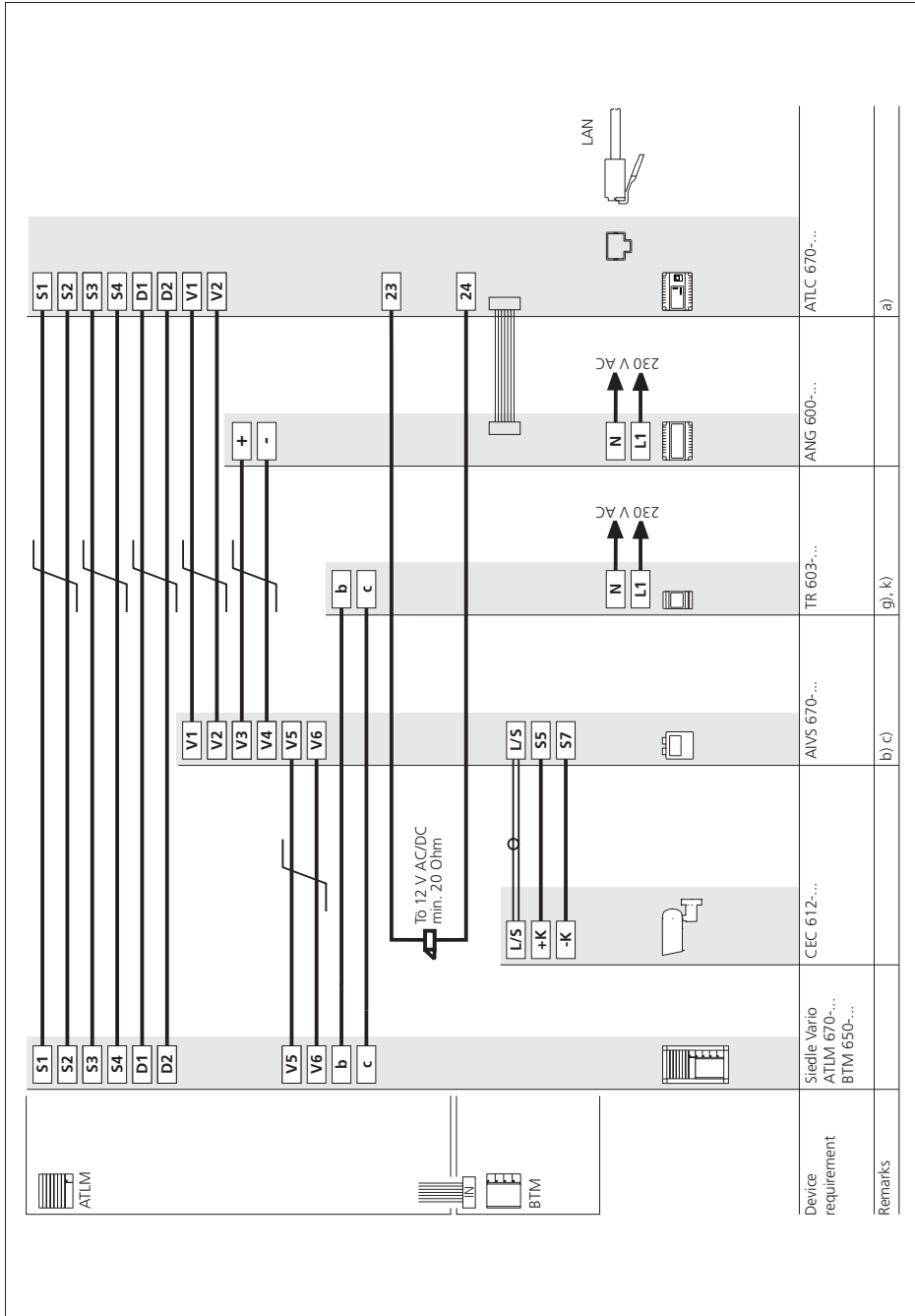

Functional

Calling and speech between door stations and the connected Access indoor call stations. The external camera discreetly surveys the access area from the background.

An existing call can not be listened in to or viewed by other Access indoor call stations. Door release button for the door release function and 7 other buttons which can be assigned any optional functions. The definition of functions and the relevant buttons take place during configuration of the server which assumes the function of central overall system administrator. The number of Access users is determined by the server. Connection facility for a storey call button (ERT) for calling an apartment door and potential-free contact is available as standard. Different ringtones for calling from the front door, the apartment door, concierge or internal call.

Supplementary functions

- Internal calls and speech communication between Access indoor call stations are possible.
- Connection of an analogue camera to the ATLC 670-... via the interface AIVS 670-...
- Concierge function as central interface, e.g. at the reception
- 8 freely selectable ring tones
- Call forwarding
- Call follow-me function
- Parallel door and storey call
- Group formation possible
- Selective dialling of the door station using additional free buttons
- Central video memory module (server) possible

Remarks

- a)** If door release or door control systems are installed which do not correspond to 12 V AC/DC min. 20 Ohm, the system will require an intermediate relay.
- b)** Distance between the camera and AIVS 670-... max. 10 m
- c)** Pay attention to the switch setting for the supply voltage 12/24 V DC
- g)** Is only required if more than 26 BTM 650-... units are installed at this door station.



- k)** If the BTM 650-... units are supplied via a separate transformer, no connection between c1 and c/b1 and b may exist at the terminal block.

Installation

AS-AV with Access custom-fit door loudspeaker and external camera

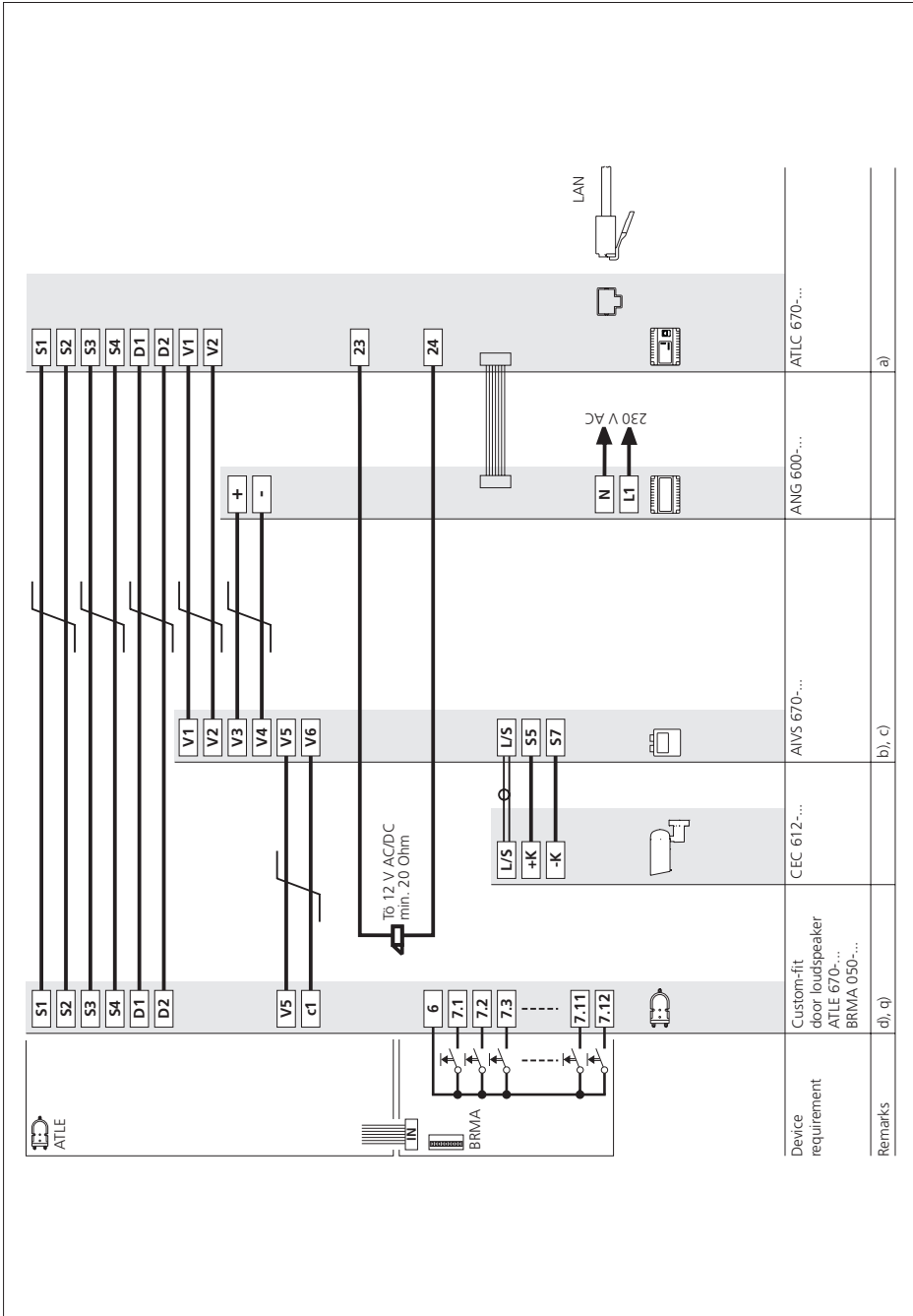

Functional

Calling and speech between door stations and the connected Access indoor call stations. The external camera discreetly surveys the access area from the background.

An existing call can not be listened in to or viewed by other Access indoor call stations. Door release button for the door release function and 7 other buttons which can be assigned any optional functions. The definition of functions and the relevant buttons take place during configuration of the server which assumes the function of central overall system administrator. The number of Access users is determined by the server. Connection facility for a storey call button (ERT) for calling an apartment door and potential-free contact is available as standard. Different ringtones for calling from the front door, the apartment door, concierge or internal call.

Supplementary functions

- Internal calls and speech communication between Access indoor call stations are possible.
- Connection of an analogue camera to the ATLC 670-... via the interface AIVS 670-...
- Concierge function as central interface, e.g. at the reception
- 8 freely selectable ring tones
- Call forwarding
- Call follow-me function
- Parallel door and storey call
- Group formation possible
- Selective dialling of the door station using additional free buttons
- Central video memory module (server) possible

Remarks

a) If door release or door control systems are installed which do not correspond to 12 V AC/DC min. 20 Ohm, the system will require an intermediate relay.

b) Distance between the camera and AIVS 670-... max. 10 m

c) Pay attention to the switch setting for the supply voltage 12/24 V DC

d) A maximum of 12 call buttons can be connected at one BRMA 050-...

The maximum configuration is 16 BRMA 050-... units/192 buttons.

q) The internal wiring of the Classic door station is completed on site by the customer.

Installation

AS-AV with Access custom-fit door loudspeaker and Access camera module

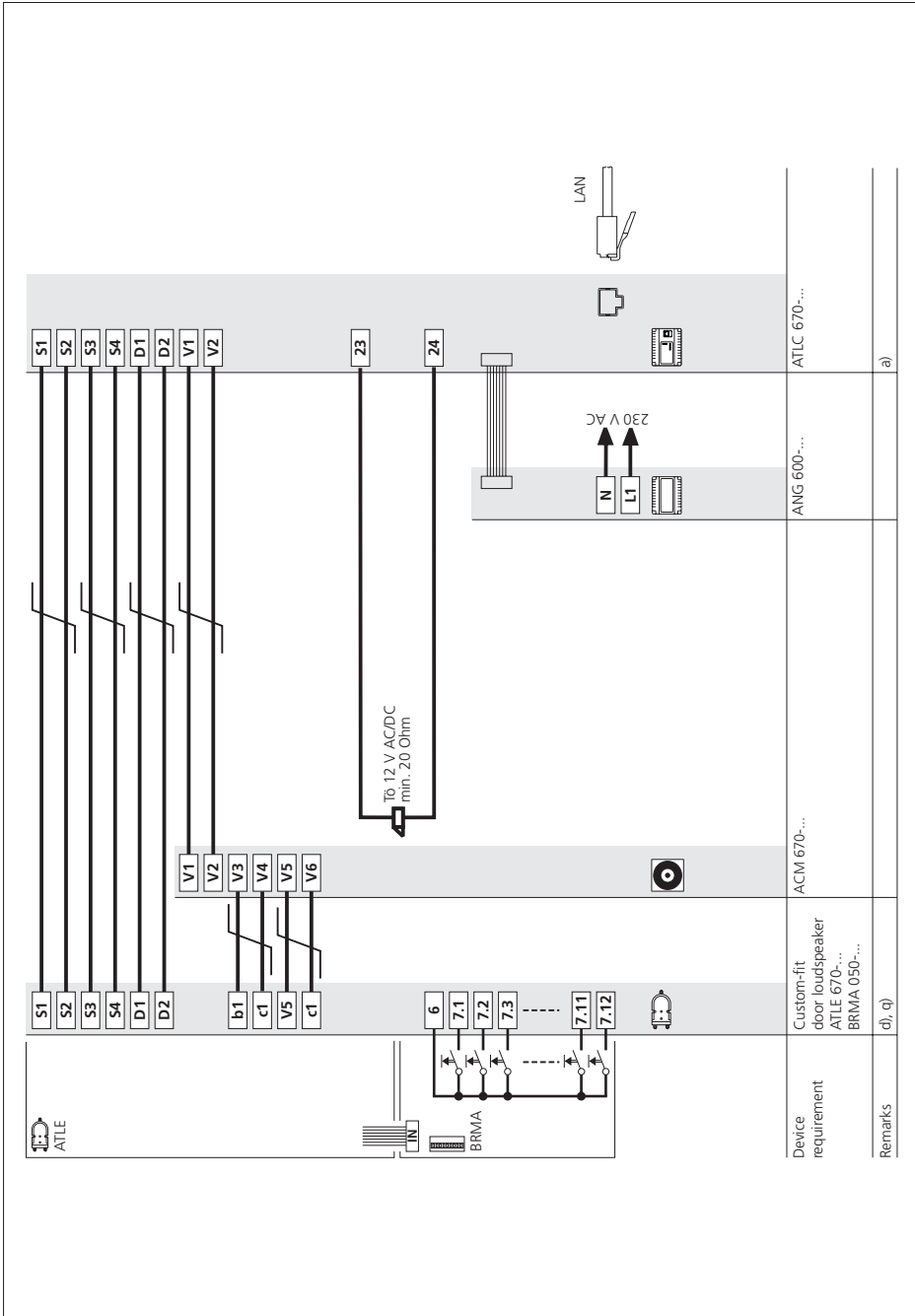

Functional

Calling, speech and video functions between door station and the connected Access indoor call stations. An existing call can not be listened in to or viewed by other Access indoor call stations. Door release button for the door release function and 7 other buttons which can be assigned any optional functions. The definition of functions and the relevant buttons take place during configuration of the server which assumes the function of central overall system administrator. The number of Access users is determined by the server. Connection facility for a storey call button (ERT) for calling an apartment door and potential-free contact is available as standard. Different ringtones for calling from the front door, the apartment door, concierge or internal call.

Supplementary functions

- Internal calls and speech communication between Access indoor call stations are possible.
- Connection of an analogue camera to the ATLC 670-... via the interface AIVS 670-...
- Concierge function as central interface, e.g. at the reception
- 8 freely selectable ring tones
- Call forwarding
- Call follow-me function
- Parallel door and storey call
- Group formation possible
- Selective dialling of the door station using additional free buttons
- Central video memory module (server) possible

Remarks

a) If door release or door control systems are installed which do not correspond to 12 V AC/DC min. 20 Ohm, the system will require an intermediate relay.

d) A maximum of 12 call buttons can be connected at one BRMA 050-...
The maximum configuration is 16 BRMA 050-... units/192 buttons.

q) The internal wiring of the Classic door station is completed on site by the customer.

Installation

AS-AV Siedle Vario with DRM 611-...

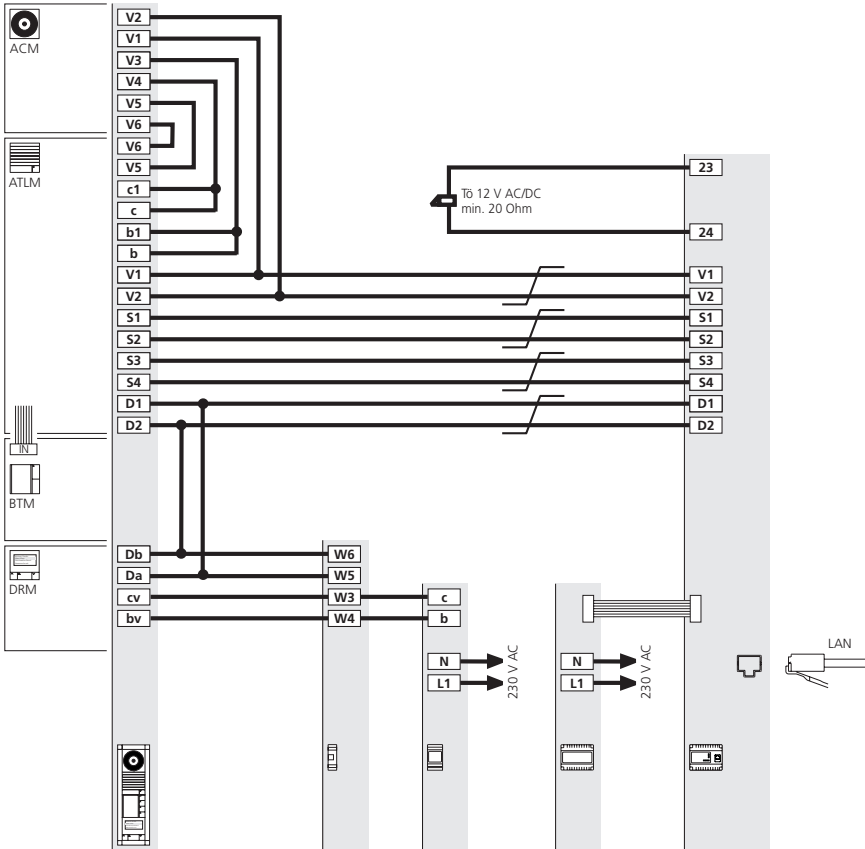

Device requirement	Siedle Vario ACM 670-... ATLM 670-... BTM 650-... DRM 611-...	ZWA 640-...	TR 603-...	ANG 600-...	ATLC 670-...
Remarks	h)	n)		a)	

Functional

Calling, speech and video functions between door station and the connected Access indoor call stations. With the call button module, the call goes to a central location (concierge) or via the display call module selectively to the required user. An existing call can not be listened in to or viewed by other Access indoor call stations. Door release button for the door release function and 7 other buttons which can be assigned any optional functions. The definition of functions and the relevant buttons take place during configuration of the server which assumes the function of central overall system administrator. The number of Access users is determined by the server. Connection facility for a storey call button (ERT) for calling an apartment door and potential-free contact is available as standard. Different ringtones for calling from the front door, the apartment door, concierge or internal call.

Supplementary functions

- Internal calls and speech communication between Access indoor call stations are possible.
- Connection of an analogue camera to the ATLC 670-... via the interface AIVS 670-...
- Concierge function as central interface, e.g. at the reception
- 8 freely selectable ring tones
- Call forwarding
- Call follow-me function
- Parallel door and storey call
- Group formation possible
- Selective dialling of the door station using additional free buttons
- Central video memory module (server) possible

Remarks

- a)** If door release or door control systems are installed which do not correspond to 12 V AC/DC min. 20 Ohm, the system will require an intermediate relay.
- h)** Where there are more than 10 BTM 650-... units, an additional 12 V AC supply, for instance TR 603-..., must be installed due to the current consumption.
- n)** For programming the names, programming software PRS 602-0 and programming interface PRI 602-0 are required. The names are now entered in the display call module using the PRS 602-0.

Installation

AS-AV Siedle Vario with COM 611-...

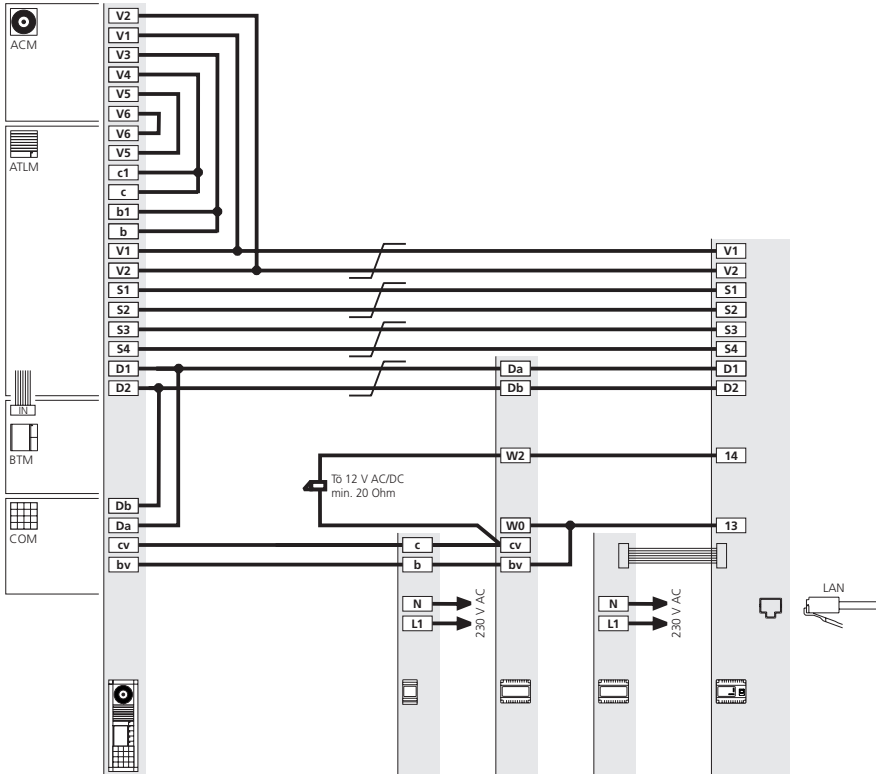

Device requirement	Siedle Vario ACM 670-... ATLM 670-... BTM 650-... COM 611-...	TR 603-...	EC 602-...	ANG 600-...	ATLC 670-...
Remarks	d)	i), k)			a)

Functional

Calling, speech and video functions between door station and the connected Access indoor call stations. With the call button module, the call goes to a central location (concierge) or via the code lock module selectively to the user whose stored code you have entered.

An existing call can not be listened in to or viewed by other Access indoor call stations. Door release button for the door release function and 7 other buttons which can be assigned any optional functions. The definition of functions and the relevant buttons take place during configuration of the server which assumes the function of central overall system administrator. The number of Access users is determined by the server. Connection facility for a storey call button (ERT) for calling an apartment door and potential-free contact is available as standard. Different ringtones for calling from the front door, the apartment door, concierge or internal call.

Supplementary functions

- Internal calls and speech communication between Access indoor call stations are possible.
- Connection of an analogue camera to the ATLC 670-... via the interface AIVS 670-...
- Concierge function as central interface, e.g. at the reception
- 8 freely selectable ring tones
- Call forwarding
- Call follow-me function
- Parallel door and storey call
- Group formation possible
- Selective dialling of the door station using additional free buttons
- Central video memory module (server) possible

Remarks

a) If door release or door control systems are installed which do not correspond to 12 V AC/DC min. 20 Ohm, the system will require an intermediate relay.

d) The COM 611-... is always available for placing calls (by code). An additional Easikey controller is only required for this door station if additional control functions have to be carried out.

i) This is required with the EC 602-... or when more than one BTM 650-... is installed in the door station.



k) If the BTM 650-... units are supplied via a separate transformer, no connection between c1 and c/b1 and b may exist at the terminal block.

Installation

AS-AV external camera with video distributor

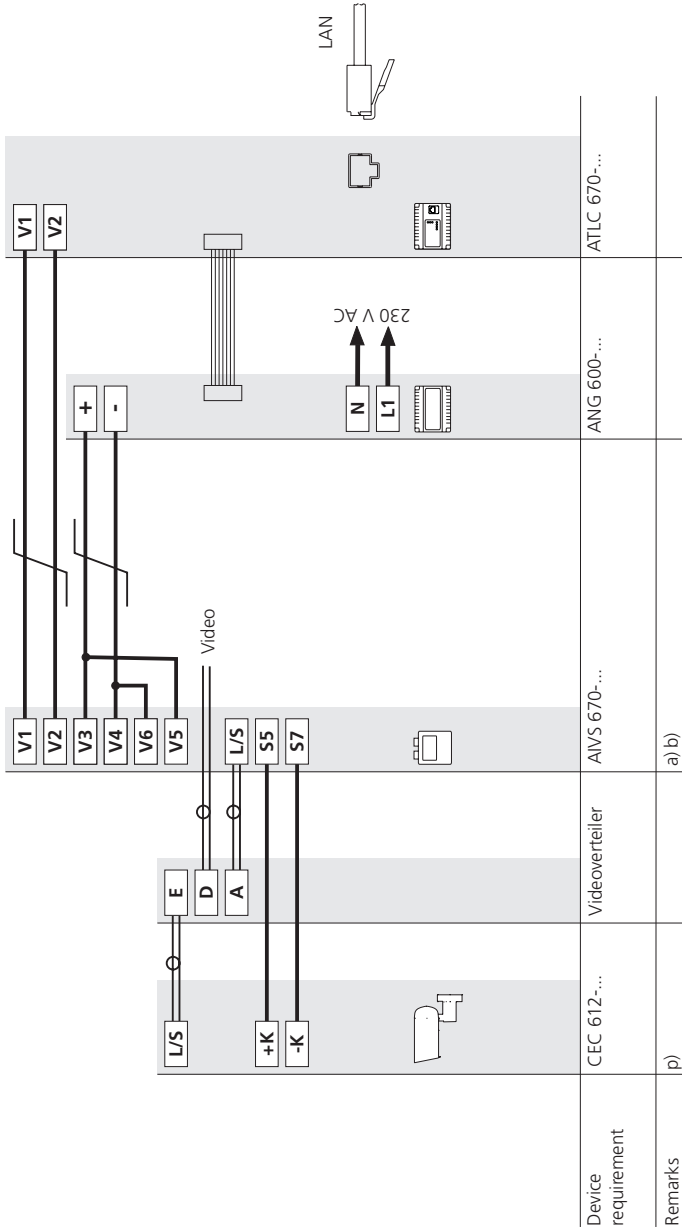

Functional

Viewing/monitoring a certain area using an Access indoor call station set up for the purpose.

Each camera is specifically selected via the ATLC 670-... The number of cameras/Access users is limited by the server used.

Using the buttons defined during configuration, each camera can be selected. This function must be configured for every authorized user.

The video signal is split using the video distributor supplied by the customer. This allows the signal to be shown on a continuous surveillance monitor and also on an event-controlled basis on an assigned Access indoor device.

Terminal assignment of the video distributor provided by the customer:

E = Input

D = Throughput

A = Output

Remarks

a) Distance between the camera and AIVS 670-... max. 10 m

b) Pay attention to the switch setting for the supply voltage 12/24 V DC

p) Camera in continuous operation

Installation

AS-AV external camera

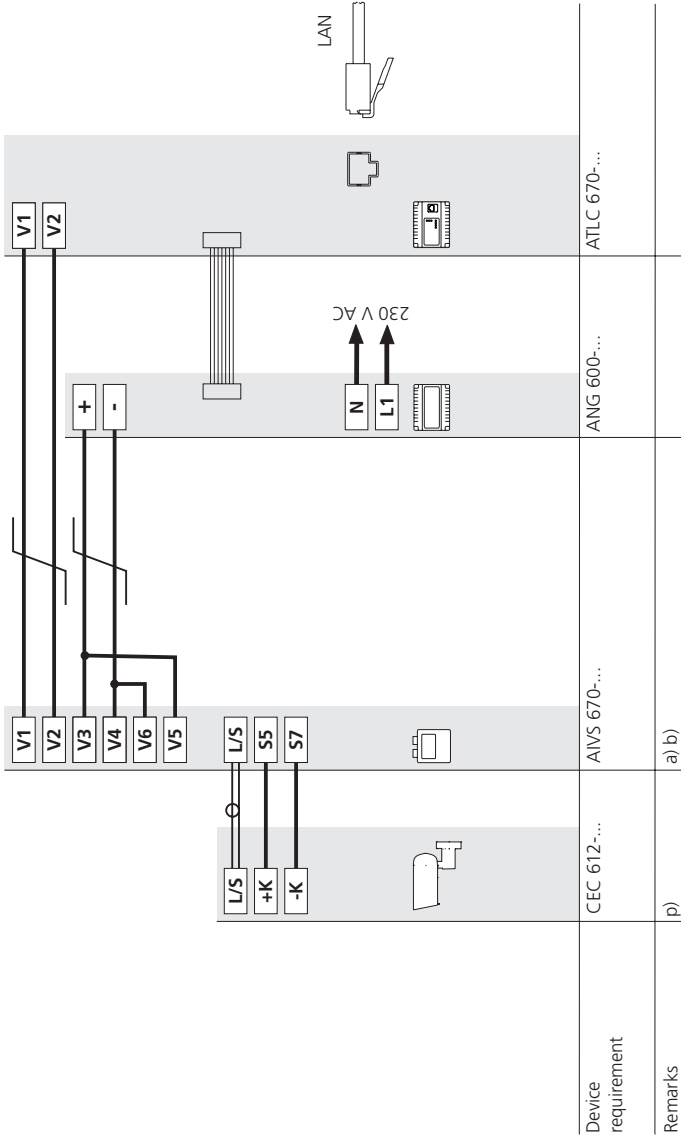

Functional

Viewing/monitoring a certain area using an Access indoor call station set up for the purpose.

Each camera is specifically selected via the ATLC 670-... The number of cameras/Access users is limited by the server used.

Using the buttons defined during configuration, each camera can be selected. This function must be configured for every authorized user.

Remarks

- a)** Distance between the camera and AIVS 670-... max. 10 m
- b)** Pay attention to the switch setting for the supply voltage 12/24 V DC
- p)** Camera in continuous operation

Installation

AS-AA Siedle Vario

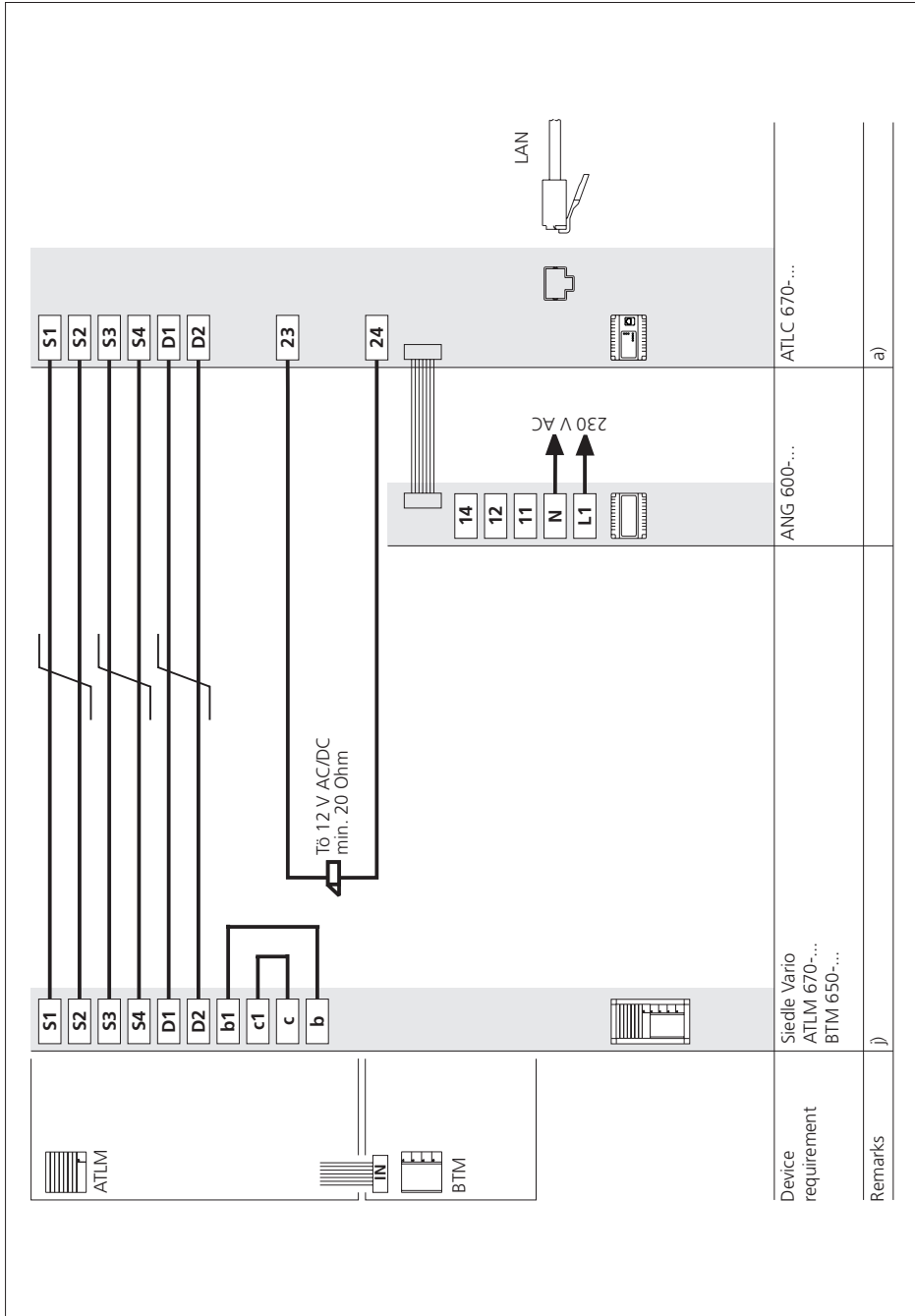

Functional

Calling and speech between door stations and the connected Access indoor call stations.

Other Access indoor call stations are not able to listen in to an existing call. Door release button for the door release function and 7 other buttons which can be assigned any optional functions. The definition of functions and the relevant buttons take place during configuration of the server which assumes the function of central overall system administrator. The number of Access users is determined by the server.

Connection facility for a storey call button (ERT) for calling an apartment door and potential-free contact is available as standard.

Different ringtones for calling from the front door, the apartment door, concierge or internal call.

Remarks

a) If door release or door control systems are installed which do not correspond to 12 V AC/DC min. 20 Ohm, the system will require an intermediate relay.

j) From 26 BTM 650-... units, an additional 12 V AC, for instance TR 603-... must be installed due to the current consumption.

Installation

AS-AA with Access custom-fit door loudspeaker

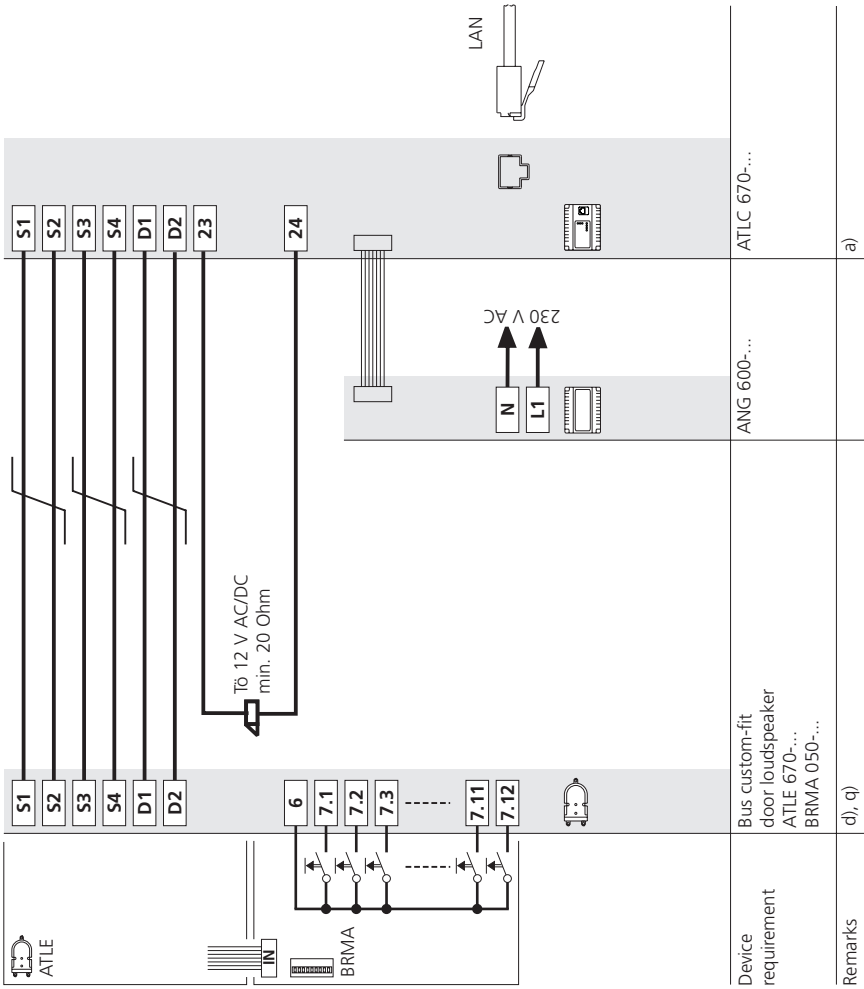

Functional

Calling and speech between door stations and the connected Access indoor call stations.

Other Access indoor call stations are not able to listen in to an existing call. Door release button for the door release function and 7 other buttons which can be assigned any optional functions. The definition of functions and the relevant buttons take place during configuration of the server which assumes the function of central overall system administrator. The number of Access users is determined by the server.

Connection facility for a storey call button (ERT) for calling an apartment door and potential-free contact is available as standard.

Different ringtones for calling from the front door, the apartment door, concierge or internal call.

Remarks

a) If door release or door control systems are installed which do not correspond to 12 V AC/DC min. 20 Ohm, the system will require an intermediate relay.

d) A maximum of 12 call buttons can be connected at one BRMA 050-...

The maximum configuration is 16 BRMA 050-... units/192 buttons.

q) The internal wiring of the Classic door station is completed on site by the customer.

Installation

Storey call button, customer's own signalling device

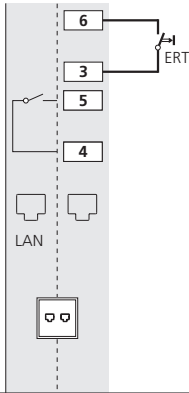

Device requirement	RJ45 8/8
Remarks	e)

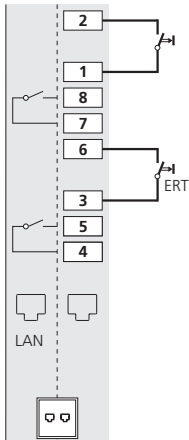

Device requirement	RJ45 8/8
Remarks	e), f)

Functional

A storey call button can be connected as standard to every Access indoor call station. To guarantee call differentiation between door and storey calls, a different acoustic signal is issued for the storey call. The selection of signals is defined by the administrator during configuration.

The storey call button is connected via the RJ45 8/8 (8) telecom socket. The left-hand jack is generally used for the LAN network. The storey call button and if applicable the customer's own existing signalling device are connected using the right-hand jack.

Remarks

e) A suitable intermediate relay may be required for the customer's own existing signalling device.

f) By mounting accessory AZIO 870-... terminals 1 and 2 as well as 7 and 8 of the right-hand RJ45 telecom socket are occupied, as listed in the terminal assignment. The terminal assignment changes if a different accessory is mounted.



An indoor device may only be connected to the network using an RJ45 8/8 (8) network socket.

Terminal assignment

Link RJ45 socket

1 - 8 LAN

Right RJ45 socket

3 Storey call button ERT
6

4 Switching contact
5 30 V, 1 A

1 Input via
2 potential-free contact

7 Switching contact
8 30 V, 1 A

Information on programming

The Access system is programmed using a computer running the current Firefox browser at the server. The necessary programming is carried out directly at the server using the web user interface. Any necessary support for programming-related questions can be found in the help function.

Careful documentation of the system and any configuration-related requirements with an indication of the device mounting locations is particularly helpful and should be made a constituent part of the operating manual without fail.

Operating manual

To ensure that you can retrace the status of a system at any time, an operating manual should be drawn up and regularly maintained.

Siedle recommends compiling an operating manual to document the network and the Access system. The operating manual must be accessible to servicing personnel and contain fundamental information:

- Contact data of the system administrator (with deputization arrangements)
- Hardware list
- Documentation of the server configuration
- Server backup
- Documentation of the software status and device configuration
- Construction plan with structured cabling (LAN policy)
- Issue of passwords and possibilities for remote login access
- IP address and device names of the network components
- Process descriptions (e.g. creating a user, exchanging devices etc.)
- Documentation of changes made
- Documentation of errors/remedy of errors

Licence management

Through the purchase of additional licences, more services can be purchased for specific devices or for the system as a whole. These can be purchased exclusively through our Access Certified Partners, who will then enable the licences for you. To find the responsible Access Certified Partner, go to www.siedle.com

Initial commissioning/Login

Requirements:

PC with installed browser (Firefox, latest version)

The PC and Access Server must be in the same network/linked using a crossover cable

Registration at the administrator user interface

Login via a web interface takes place on the Access server. For this, enter the IP address of the server. This is defined as 192.168.1.1 in the as-delivered status.

The administrator set in the factory has the account name „admin“ and the password „admin“. In addition, a randomly generated security code is required with each login.

This is entered in the security code field. If the security code is not legible, click onto it to generate a new code. Start the login process using the „login“ button. Further configuration is prompted by the server instructions and using the integrated help function.

Kontoname	<input type="text" value="admin"/>	<div style="border: 1px solid black; padding: 20px; text-align: center; font-size: 2em;">hsnc</div>
Kennwort	<input type="password" value="••••"/>	
Sicherheitscode	<input type="text" value="hsnc"/>	
<input type="button" value="Anmelden"/>		<input type="button" value="Abbrechen"/>

<http://www.siedle.de>

Servicing

Service requirement

Access systems are serviced by the regional Access Certified Partner (service specialists). Customers/administrators request this services as the need arises.

For services specialists, access must be afforded to all parts of the system at all times. The administrator and all necessary documents appertaining to the system must be available for the duration of the servicing work.

Safety remarks



Mounting, installation and servicing work on electrical devices may only be performed by a suitably qualified electrician. Failure to observe this regulation could result in the risk of serious damage to health or fatal injury due to electric shocks.

Electrical voltage



As a result of electrostatic charging, direct contact with the circuit board can result in destruction of the device. Direct contact with the circuit board must therefore be avoided.

Exchanging devices

All devices which are connected directly to the network (indoor devices and ATLC 670-...) can be exchanged in running operation.

Procedure:

- The administrator overwrites the MAC address for the device with the MAC address of the new replacement device in the server.
- Exchange the defective device. The configuration remains unchanged, making the function identical with the predecessor device.



Exchanging ATLM/ATLE 670-...

Procedure:

- Only the line rectifier which supplies the ATLC 670-... has to be disconnected from the mains. The Access system can remain operational.
- Exchange the defective ATLM/ATLE 670-...
- Switch the line rectifier back on. The system is now completely ready to resume operation. No configuration is required.

Exchanging a defective server AS 670-...

Procedure:

- Sever all connections to the mains and the power supply.
- Exchange the defective server and restore all the connections
- Set up the supplied licences on the new server
- Restore the backup of the current configuration. If no backup exists, the system must be reconfigured.

Update process

The update is initialized by the administrator and centrally executed at the server for all the devices. It is not possible to carry out an individual update of a single internal device or the server.

During the update process, the entire system is non-operational. No calls or functions can be initiated or received. Updates should therefore be carried out during periods of minimal activity and with sufficient advance notice. The update operation of the internal devices is optically displayed by all the buttons lighting up in yellow. After the update is complete, the devices are automatically restarted.



During the update process, the power supply to the devices must not be interrupted, as this can result in damage. In this case, a repeat update is no longer possible, and the devices will have to be sent in for repair.

Start process

The start process can be initiated centrally by the administrator at the server. Unplugging and reconnecting the internal devices also initiates a restart. The Access door loudspeaker controller can be restarted by briefly disconnecting the relevant line rectifier or by actuating the reset button. The reset button can only be accessed by opening the housing. A restart of the internal devices is signalled by a yellow flashing light, starting with button 8 and ending with button 6, and the display lights up in white. If the start is successful and when the device has received all the information from the server, the system goes to the operating status. In the event of a fault, e.g. the internal device is not configured, all the buttons light up continuously in red.

LED displays

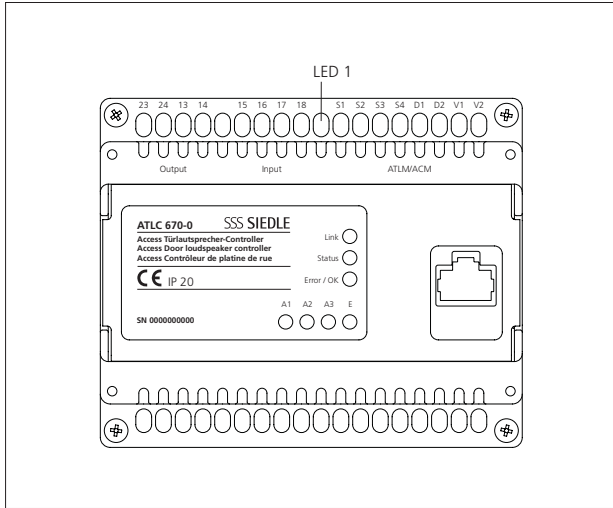

ATLC 670-0

LED display	LED operating status	Function
LED 1	off	no operating voltage
	lights up in green	operating voltage applied
Link	lights up in green	connection to switch exists
	flashes green	data communication with the device
	off	no connection to the switch
Status	lights up in green	Vario bus ready for operation
	flashes green	data communication in the Vario bus
Error/OK	lights up briefly in green	after Power On for around 5 seconds
	flashes green	during ramp-up, flashing starts up appr. 20 seconds after Power On
	lights up in green	ATLC is logged in at the server
	lights up in red	error logging into server
A1	lights up in green	output 1 HIGH (DR)
	off	output 1 LOW (DR)
A2	lights green	output 2 HIGH
	off	output 2 LOW
A3	lights up in green	output 3 HIGH (LI)
	off	output 3 LOW
E	lights up in green	input 1 HIGH (LI)
	off	input 1 LOW

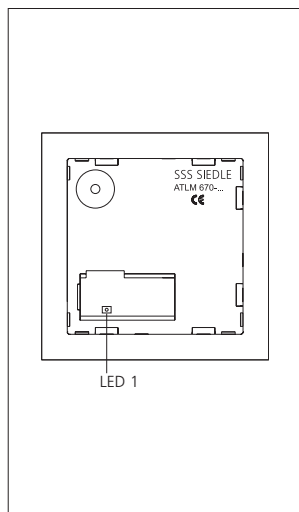
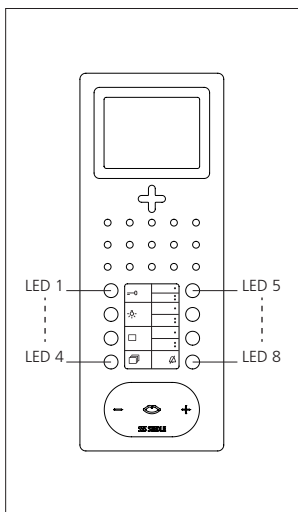
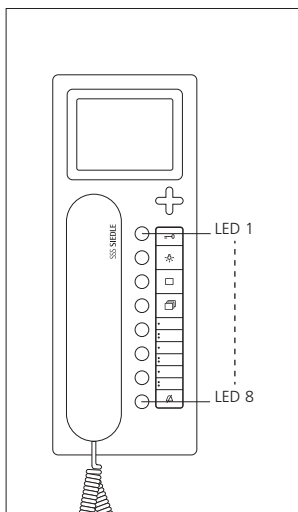

AHTV/AHFV 670-0

LED display	LED operating status	Function
LED 8	flashes yellow off	Searching for the server server found
LED 7	flashes yellow off	loading configuration from server export successfully completed
LED 6	flashes yellow off	login to server login successful
LED 1-8	lights up briefly in yellow lights up in red off	after Power On for around 5 seconds error logging into server successfully logged into server



LED 1-8	Flashes for appr. 2 mins. in yellow	Software update for terminals
---------	-------------------------------------	-------------------------------

ATLM 670-0

LED display	LED operating status	Function
LED 1	flashes 3x in green Off Lights up green Flashes briefly 3x in green	Device starts up Ramp up successfully completed Audio active unassigned/unprogrammed call button is actuated

Glossary

Telecom socket RJ45 8/8

The left-hand jack is used for the LAN network. The storey call button and if applicable the customer's own existing signalling device are connected using the right-hand jack.

Operating manual

Current system documentation including all hardware and software requirements.

CAT5

Twisted pair cable, shielded

Storey call button

The storey call button (ERT) is used to call from a storey door to the internal device.

Indoor devices

Call stations and accessories as an intercom to the door area.

LAN

Local Area Network Network which connects the system components.

Licences

Enabling performance characteristics which are additionally managed centrally on the server.

POE

Power over Ethernet supplies all internal devices.

System components

All devices which are connected together in the system.

Software

The system software is pre-installed on the server. The software for the concierge and virtual telephone functions or for connection to external systems must be additionally purchased if required.

Switch

Coupling element which links the network components and segments.

Door area

In the door area are all devices connected to the system via an Access door loudspeaker controller ATLC 670-... This also includes cameras which monitor different areas.

Doormatic

Programmable function which actuates a contact in the ATLC 670-... with a time delay (door release).

Distribution

This is the place where several devices are switched together (connected). This often takes place in a distributor cabinet, although this is not mandatory. Large distribution panels can fill an entire room.

Index

ACM 670-...	10
AHF 870-...	12
AHFV 870-...	13
AHT 870-...	12
AHTV 870-...	12
AIVS 670-...	11
ALFA 270-...	18
ALFC 270-...	18
ALFS 270-...	18
ALFT 270-...	18
ALFV 270-...	18
ALKNX 270-...	18
ALT 270-...	18
ANG 600-...	14
AS 670-...	15
ASC 170-...	17
ASHT 170-...	16
ASM 170-...	17
ATLC 670-...	14
ATLC/NG 670-...	14
ATLE 670-...	9
ATLM 670-...	8
AZA 870-...	13
AZIO 870-...	13
AZTV 870-...	13
BRMA 050-01	9
BTM 650-...	8
CEC 612-...	10, 32, 34
COM 611-...	8, 38
DRM 611-...	8, 36
KAWG 950-...	10
Siedle Cassic	9, 22
Siedle Steel	9, 24
TR 602-...	14
TR 603-...	14

Technical additions or printing errors do not constitute grounds for compensation claims.

After-sales service:
Telephone +49 7723 63-540
access@siedle.de

To supplement this system manual, you will find the latest edition in the download area of our website on www.siedle.com

SSS SIEDLE

S. Siedle & Söhne
Telefon- und Telegrafengeräte OHG

Postfach 1155
78113 Furtwangen
Bregstraße 1
78120 Furtwangen

Telefon +49 7723 63-0
Telefax +49 7723 63-300
www.siedle.de
info@siedle.de

© 2011/08.13
Printed in Germany
Best. Nr. 0-1101/142961 EN